

OPERATOR'S MANUAL

WX540 – Serial numbers 273166 to 274339, 100008 to 100206, and 1100000 to 1100203
WX540L – Serial numbers 2E9US1113KS273164 to 2E9US1111NS274337, 100014 to 100210,
and 1100000 to 1100203

WX540, WX540L Trailer Wood Splitter

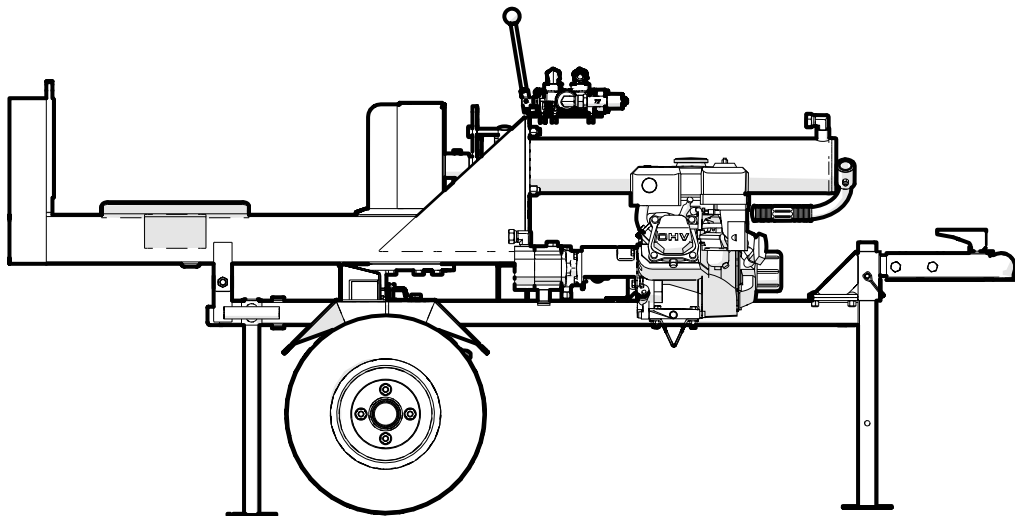

1. Introduction

1.1 Foreword

Congratulations on choosing a **Wallenstein Trailer Wood Splitter!**

This high-quality machine is designed and manufactured to meet the needs of an efficient wood splitting operation.

This manual covers the Wallenstein 20-ton WX540 trailer wood splitters. The WX540 model features horizontal and vertical splitting.

Model Variants Covered in this Manual

- **WX540**
- **WX5450L** (stop, turn signal, tail lights)

Units of measurement in Wallenstein Equipment technical manuals are written as:
US Customary (SI metric).

Keep this manual handy for frequent reference and to pass on to new operators or owners. Call your Wallenstein dealer or distributor if you need assistance, information or additional copies of the manuals.

Wallenstein Equipment Inc. • © 2020. All rights reserved.

No part of this work may be copied, reproduced, replaced, distributed, published, displayed, modified, or transferred in any form or by any means except with the prior permission of Wallenstein Equipment Inc.

Review all safety, operation and maintenance information contained in this manual.

WARNING!

Do not attempt to start or operate the machine without thoroughly reviewing this manual for safe and proper operation.

Always keep this manual with the machine.

W034



Table of Contents

1. Introduction.....	2	7. Service and Maintenance.....	32
1.1 Foreword.....	2	7.1 Maintenance Safety.....	32
1.2 Delivery Inspection Report.....	4	7.2 Fluids and Lubricants.....	32
1.3 Serial Number Location.....	5	7.3 Maintenance Schedule.....	33
1.4 Warranty.....	6	7.4 Grease Points.....	33
1.5 Decal Information.....	7	7.5 Hydraulic Oil – Changing.....	35
2. Safety.....	8	7.6 Hydraulic Oil Filter – Changing.....	35
2.1 Safety Alert Symbol.....	8	7.7 Engine Air Cleaner.....	36
2.2 Signal Words.....	8	7.8 Electrical System – General.....	36
2.3 Why is SAFETY important?.....	9	8. Troubleshooting.....	37
2.4 Safety Rules.....	9	9. Specifications.....	38
2.5 Equipment Safety Guidelines.....	10	9.1 Machine Specifications.....	38
2.6 Safety Training.....	10	9.2 Common Bolt Torque Values.....	39
2.7 Refueling Safety.....	10	9.3 Hydraulic Fitting Torque.....	40
2.8 Tire Safety.....	10	9.4 Wheel Lug Torque.....	40
2.9 Hydraulic Safety.....	10	10. Alphabetical Index.....	41
2.10 Gas Engine Safety.....	11		
2.11 Being Prepared.....	12		
3. Safety Signs.....	14		
3.1 Safety Sign Locations.....	14		
3.2 Safety Sign Explanations.....	15		
4. Familiarization.....	16		
4.1 To the New Operator.....	16		
4.2 Machine Components.....	17		
5. Controls.....	18		
5.1 Engine.....	18		
5.2 Hydraulic Valve.....	19		
5.3 Stroke Limiter Accessory.....	21		
6. Operating Instructions.....	22		
6.1 Operating Safety.....	22		
6.2 Before Starting the Engine.....	22		
6.3 Pre-operation Checklist.....	23		
6.4 Machine Break-In.....	23		
6.5 Engine Oil Level Check.....	24		
6.6 Hydraulic Oil Level Check.....	24		
6.7 Fuel Level Check.....	25		
6.8 Machine Set-up.....	25		
6.9 Starting the Engine.....	26		
6.10 Stopping the Engine.....	26		
6.11 Log Placement.....	27		
6.12 Splitting Wood.....	27		
6.13 Vertical Splitting.....	28		
6.14 Transporting.....	29		
6.15 Connecting a Tow Vehicle.....	30		
6.16 Storing the Wood Splitter.....	31		
6.17 Removing from Storage.....	31		

1.2 Delivery Inspection Report

WALLENSTEIN WX540, WX540L Trailer Wood Splitters

To activate warranty, register your product online at
<http://www.wallensteinequipment.com>

Customer's Name _____

Contact Name _____

Dealer Name _____

(_____) _____
Phone Number

Serial Number _____

_____/_____/_____
Delivery Date

I have thoroughly instructed the buyer on the equipment care, adjustments, safe operation and applicable warranty policy and reviewed the manual.

Dealer's Rep. Signature _____

_____/_____/_____
Date

The product manuals have been received by me and I have been thoroughly instructed as to care, adjustments, safe operation and applicable warranty policy.

Owner's Signature _____

_____/_____/_____
Date

✓	Pre-delivery Inspection
Inspect for damage from shipping. Immediately contact the shipping company if damage is found.	
Trailer Wood Splitter	
	Hydraulic Valve Control Function
	Hydraulic Cylinder Function
	Hydraulic Reservoir level
	Engine Oil Level
	Horizontal / Vertical Pivot Moves Freely (as equipped)
	Front and Rear Support Stands Move freely
	All fasteners are Tight
	Lubricate all Pivot Points (as equipped)
	Check that all Hydraulic Connections are tight
	Review Operating and Safety Instructions
Safety Checks	
	All Safety Decals Installed
	Guards and Shields Installed and Secured
	Check Function of Brake and Signal Lighting
	Supports Function Correctly
	Safety Chain on Hitch
	Retainer Installed Through Ball Hitch
	Review Operating and Safety Instructions

1.3 Serial Number Location

Always provide the model and serial number of your Wallenstein product when ordering parts, or requesting service or other information. The product information plate location is shown in the illustration.

For future convenience, record the product Model and Serial Number in the spaces provided below.

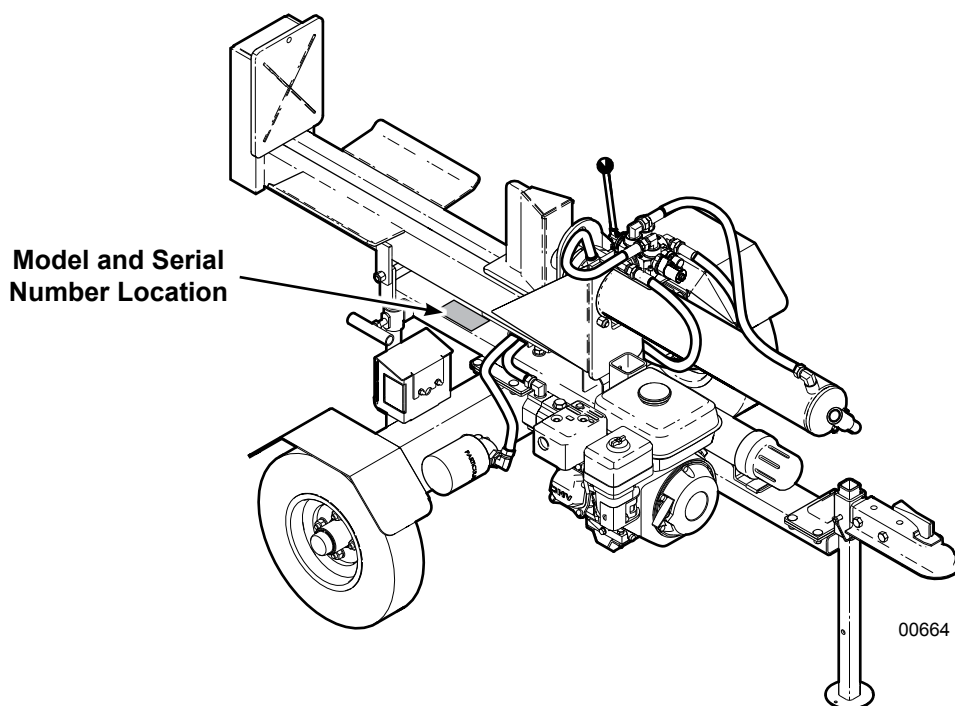

Fig. 1 – Product Information Plate Location

Record Product Information Here	
Model:	
Serial Number:	

1.4 Warranty



LIMITED WARRANTY

Wallenstein products are warranted to be free of defects in materials and workmanship under normal use and service, for a period of

Five Years for Consumer Use

Two Years for Commercial/Rental Use

from the date of purchase, when operated and maintained in accordance with the operating and maintenance instructions supplied with the unit. Warranty is limited to the repair of the product and/or replacement of parts.

This warranty is extended only to the original purchaser and is not transferable.

Repairs must be done by an authorized dealer. Products will be returned to the dealer at the customer's expense. Include the original purchase receipt with any claim.

This warranty does not cover the following:

- 1) Normal maintenance or adjustments
- 2) Normal replacement of wearable and service parts
- 3) Consequential damage, indirect damage, or loss of profits
- 4) Damages resulting from:
 - Misuse, negligence, accident, theft or fire
 - Use of improper or insufficient fuel, fluids or lubricants
 - Use of parts or aftermarket accessories other than genuine Wallenstein parts
 - Modifications, alteration, tampering or improper repair performed by parties other than an authorized dealer
 - Any device or accessories installed by parties other than an authorized dealer
- 5) Engines. Engines are covered by the manufacturer of the engine for the warranty period they specify. For the details of your engine warranty, see your engine owner's manual. Information about engine warranty and service is also available in the FAQ section at www.wallensteinequipment.com

1.5 Decal Information

When getting familiar with the Wallenstein product, notice that there are numerous decals located on the machine. There are different types of decals for safety, information, and product identification. The following section explains what they are for and how to read them.

Safety Decals are pictorial with a yellow background and generally two panel. The top panel shows the safety alert (the potential hazard) and the bottom panel shows the message (how to avoid the hazard).

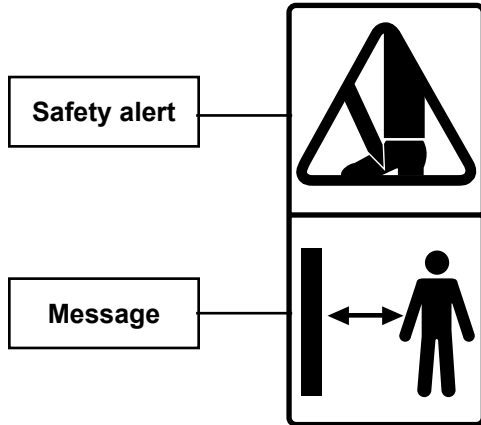

Safety Notice Decals are pictorial with a blue background and generally rectangular with single or multiple symbols. This decal informs what Personal Protective Equipment is required for safe operation.



Informative Decals are generally pictorial with a white background and can vary in the number of panels. This type of decal provides additional information to the operator or explains the operation of a control.

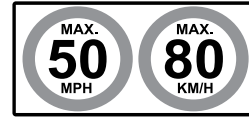

Product Decals indicate machine model and serial number, and other important information.

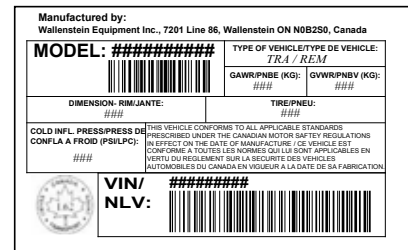

Maintenance Decals have a green background and can vary to the number of panels. This decal shows a type maintenance required and frequency interval.

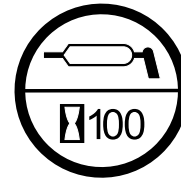

See the section on safety signs for safety decal definitions. For a complete illustration of decals and decal locations, download the parts manual for your model product at www.wallensteinequipment.com.

2. Safety

2.1 Safety Alert Symbol

This Safety Alert Symbol means:

ATTENTION! BE ALERT!
YOUR SAFETY IS INVOLVED!

The **Safety Alert Symbol** identifies important safety messages on the Wallenstein wood splitter and in the manual. When you see this symbol, be alert to the possibility of personal injury or death. Follow the instructions in the safety message.



2.2 Signal Words

The signal words **DANGER**, **WARNING** and **CAUTION** determine the seriousness level of the warning messages in this manual. The appropriate signal word for each message in this manual has been selected using the following guidelines:

DANGER –

Indicates an imminently hazardous situation that, if not avoided, **will** result in death or serious injury. This signal word is to be limited to the most extreme situations typically for machine components which, for functional purposes, cannot be guarded.

WARNING –

Indicates a potentially hazardous situation that, if not avoided, **could** result in death or serious injury, and includes hazards that are exposed when guards are removed. It may also be used to alert against unsafe practices.

CAUTION –

Indicates a potentially hazardous situation that, if not avoided, **may** result in minor or moderate injury. It may also be used to alert against unsafe practices.

IMPORTANT – To avoid confusing equipment protection with personal safety messages, a signal word **IMPORTANT** indicates a situation that if not avoided, could result in damage to the machine.



NOTE: *(plus text) – indicates an additional explanation for an element of information.*

2.3 Why is SAFETY important?

Three Big Reasons:

- **Accidents Disable and Kill**
- **Accidents Cost**
- **Accidents Can Be Avoided**

The policy of Wallenstein Equipment Inc. is to produce products that are safe and reliable. However, even when using well-engineered equipment, there is always an element of risk. To minimize the risks and promote safety at all times, this section of the operator's manual details a number of safety rules that must always be followed and obeyed.

YOU are responsible for the SAFE operation and maintenance of your Wallenstein Trailer Wood Splitter. **YOU** must ensure that you and anyone else who is going to use, maintain or work around the wood splitter be familiar with the operating and maintenance procedures and related safety information contained in this manual. This manual provides good safety practices that should be followed while using the wood splitter.

Remember, **YOU** are the key to safety. Good safety practices not only protect you but also the people around you. Make these practices a working part of your safety program. Be certain that **EVERYONE** using this equipment is familiar with the recommended use and maintenance procedures and follows all the safety precautions.

2.4 Safety Rules

- **DO** give operating instructions to operators or employees before allowing them to operate the machine, and **REVIEW** annually thereafter.
- **DO** read and understand ALL Safety and Operating instructions in the manual and follow them. The most important safety device on this equipment is a SAFE operator. 
- **DO** review safety related items annually with all personnel who are operating the machine or performing maintenance.

- **DO** wear appropriate Personal Protective Equipment (PPE). The suggested equipment includes but is not limited to the following:
 - Hearing Protection
 - Protective glasses, goggles or face shield
 - Heavy work gloves
 - Protective shoes with slip resistant soles

- **DO** have a first-aid kit available for use should the need arise and know how to use it.



- **DO** read and understand all safety signs located on the machine before operating, servicing, adjusting, or cleaning.
- **DO** inspect and secure all guards before starting.
- **DO** check engine intake and exhaust. Make sure they are clear of debris prior to starting the machine.
- **DO** have a fire extinguisher available for use should the need arise. Know how to use it.
- **DO** think SAFETY! Work SAFELY!



- **DO NOT** touch hot engine parts, muffler cover, hydraulic hoses, engine body, engine oil, and so on during operation or if the engine was recently shut off. Contact may cause burns.
- **DO NOT** expect a person who has not read and understood all operation and safety instructions to use the machine. An untrained operator is not qualified and is exposed to possible serious injury or death. It is the owner's responsibility to make sure to the operator has familiarity and understanding of the machine.
- **DO NOT** allow riders during transport.
- **DO NOT** risk injury or death by ignoring good safety practices.

2.5 Equipment Safety Guidelines

Always place the machine in a **Safe Condition** before performing any service work, maintenance procedures, or storage preparation.

SAFE CONDITION

- Shut off engine.
- Make sure all moving parts have stopped.
- Disconnect battery ground (-) cable.
- Block or chock wheels.

- Never use equipment with safety shields removed. Keep all shields in place. If shield removal becomes necessary for repairs, reinstall the shield prior to use.
- Replace any safety sign or instruction sign that is not readable or is missing. Location of safety signs is indicated in this manual.
- Do not allow anyone other than a responsible, properly trained and physically able person to operate this machine. This equipment is dangerous to children and persons unfamiliar with its operation.
- Do not modify the equipment in any way. Unauthorized modification may result in serious injury or death and may impair the function and life of the equipment.
- Never exceed the limits of the machine. If its ability to do the job or to do it safely is in question—**STOP IMMEDIATELY!**

2.6 Safety Training

- The best safety feature is an informed, careful operator—we ask you be that kind of operator. It is the operator's responsibility to read, understand and follow ALL safety and operation instructions in the manual.
- Train all new personnel and review instructions frequently with existing workers. Only properly trained and physically able operators should use this equipment. **A person who has not read and understood all operation and safety instructions is not qualified to use the machine.** Untrained operators expose themselves and bystanders to possible serious injury or death. If elderly people are assisting with the work, their physical limitations need to be recognized and accommodated.



- Learn the controls and how to stop the machine quickly in an emergency.
- If this machine is loaned or rented, it is the machine owner's responsibility to make certain that every operator:
 - Reads and understands the owner's manual
 - Is instructed in safe and proper use of the equipment
 - Understands and knows how to perform the Safe Condition procedure

2.7 Refueling Safety

- Engine fuel is highly flammable. Handle with care.
- Fill fuel tank outdoors.
- Stop the engine before refueling. Allow engine to cool for five minutes. Clean up spilled fuel before restarting engine.
- Do not overfill the fuel tank.
- If fuel is spilled, wipe it away carefully and wait until the fuel has dried before starting the engine.
- Do not refuel the machine while smoking or when near open flame or sparks.
- After refueling, make sure that the fuel cap is secured to prevent spillage.
- Prevent fires by keeping machine clean of accumulated trash, grease, and debris.



2.8 Tire Safety

- Failure to follow proper procedures when mounting a tire on a wheel or rim can produce an explosion which may result in serious injury or death.
- Do not attempt to mount a tire unless you have the proper equipment and experience to do the job.
- Have a qualified tire dealer or repair service perform required tire maintenance.
- When replacing worn tires, make sure they meet the original tire specifications. Never install undersized tires.

2.9 Hydraulic Safety

- Make sure that all the components in the hydraulic system are kept in good condition and are clean.

- Before applying pressure to the system, make sure all components are tight, and that lines, hoses and couplings are not damaged.
- Do not attempt any makeshift repairs to the hydraulic lines, fittings or hoses by using tapes, clamps or cements. The hydraulic system operates under extremely high pressure. Such repairs can fail suddenly and create a hazardous and unsafe condition.
- Wear proper hand and eye protection when searching for a high-pressure hydraulic leak. Use a piece of wood or cardboard as a backstop instead of hands to isolate and identify a leak.
- If injured by a concentrated high-pressure stream of hydraulic fluid, seek medical attention immediately. Serious infection or toxic reaction can develop from hydraulic fluid piercing the skin surface.
- Relieve pressure in the hydraulic system before working on it.

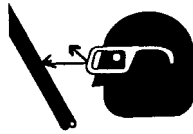

- **DO NOT** run engine above rated speeds. This may result in injury.
- **DO NOT** tamper with governor springs, governor links or other parts which may increase the governed speed.
- **DO NOT** tamper with the engine as set by the original equipment manufacturer.
- **DO NOT** check for spark with spark plug or spark plug wire removed.
- **DO NOT** crank engine with spark plug removed. If engine is flooded, crank until engine starts.
- **DO NOT** strike flywheel with a hard object or metal tool as this may cause flywheel to shatter in operation. Use proper tools to service engine.
- **DO NOT** operate engine without a muffler. Inspect periodically and replace, if necessary.
- **DO NOT** operate engine with an accumulation of grass, leaves, dirt or other combustible materials in the muffler area.
- **DO NOT** use this engine on any forest covered, brush covered, or grass covered unimproved land unless a spark arrester is installed on the muffler. The arrester must be maintained in effective working order by the operator. In the state of California, the above is required by law (Section 4442 of the California Public Resources Code). Other states may have similar laws. Federal laws apply on federal land.
- **DO NOT** touch hot muffler, engine body or cooling fins. Contact may cause burns.
- **DO NOT** run engine with air cleaner or air cleaner cover removed.

2.10 Gas Engine Safety

CAUTION!

Before starting engine, review the operating and maintenance instructions in the engine manual.

W019

- **DO NOT** operate engine in an enclosed area. Exhaust gases contain odorless and deadly carbon monoxide that can cause death by asphyxiation.
- **DO NOT** place hands or feet near moving or rotating parts.
- **DO NOT** store, spill, or use gasoline near an open flame, or devices such as a stove, furnace, or water heater which use a pilot light or devices which can create a spark.
- **DO NOT** refuel indoors where area is not well ventilated.
- **DO NOT** refuel while engine is running. Allow engine to cool for five minutes before refueling. Store fuel in approved safety containers.
- **DO NOT** remove fuel tank cap while engine is running.
- **DO NOT** operate engine if gasoline is spilled. Move machine away from the spill and avoid engine ignition until gasoline has evaporated.
- **DO NOT** smoke while filling fuel tank.
- **DO NOT** choke carburetor to stop engine. Whenever possible, gradually reduce engine speed before stopping.

Be sure to:

- Remove the wire from the spark plug when servicing the engine or equipment to prevent accidental starting. Disconnect the (-) ground wire from the battery terminal.
- Keep engine cooling fins and governor parts free of grass and other debris that can affect engine speed.
- Examine muffler periodically to be sure it is functioning effectively. A worn or leaking muffler should be repaired or replaced as necessary.
- Use fresh gasoline. Old fuel can clog carburetor and cause leakage.
- Check fuel lines and fittings frequently for cracks or leaks. Replace if necessary.

2.11 Being Prepared

- Determine where the split wood is going to be piled ahead of time. Make sure it does not interfere with safe loading of wood into the splitter.
- Precut logs so wood is ready to load into the splitter. Do not run a chain saw and the splitter at the same time.
- Determine a safe work area location:
 - Area must be clear of stones, branches or hidden obstacles that might cause a tripping, hooking or snagging hazard.
 - Ground should be firm and level.
- Operate only in daylight or good artificial light.
- Make sure machine is properly adjusted and in good operating condition.
- Store fuel well away from the wood pile.
- Perform the **Pre-operation Checklist** procedure before starting work (see *Pre-operation Checklist on page 35*).
- Do not operate on hillsides or when working area is cluttered, wet, muddy or icy to prevent slipping and tripping. Operate only on level ground.
- Position machine so prevailing winds blow engine exhaust fumes away from operator's station.
- Do not operate machine inside a closed building to prevent asphyxiation from engine exhaust.
- Stop engine when leaving the machine unattended.

3. Safety Signs

3.1 Safety Sign Locations

The types of safety signs and locations on the equipment are shown in the illustrations that follow. Good safety requires that you familiarize yourself with the various safety signs, the type of warning and the area, or particular function related to that area, that requires your SAFETY AWARENESS.

Think SAFETY! Work SAFELY!

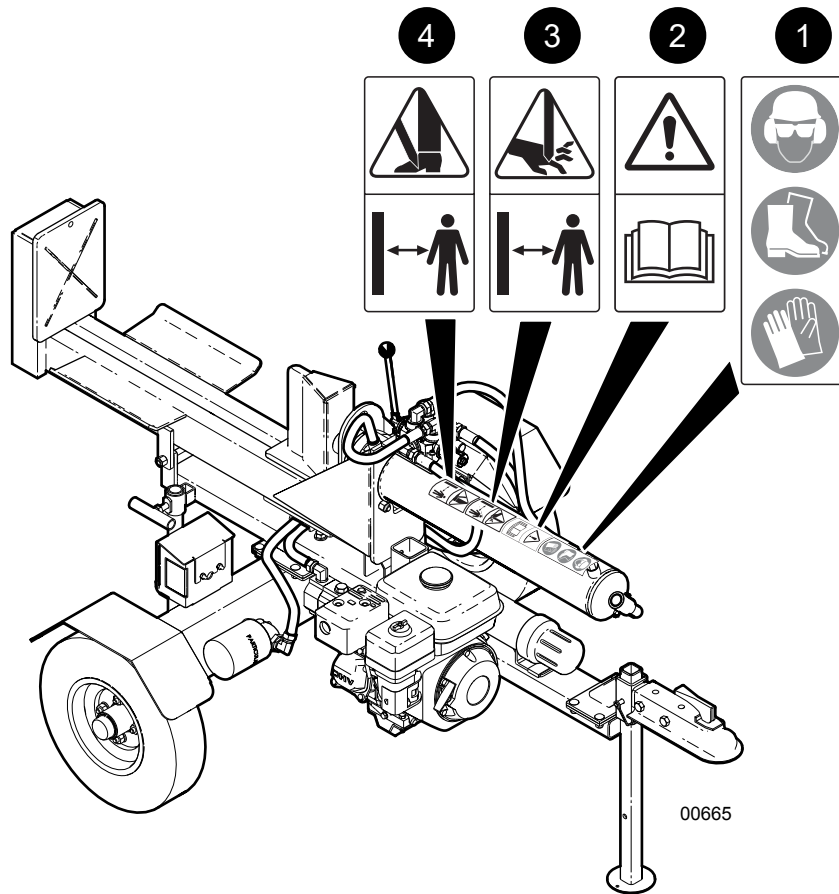

Fig. 2—Safety Decal Locations (typical for all WX500 series models)

3.2 Safety Sign Explanations

1. Warning!

Always wear appropriate Personal Protective Equipment when using this machine. For example:

- A hard hat
- Heavy gloves
- Hearing protection
- Protective shoes with slip resistant soles
- Protective glasses, goggles or face shield



2. Caution!

Refer to the operator's manual. Read ALL operating instructions in the manual and learn the meaning of ALL safety signs on the machine.

The best safety feature is an informed operator.

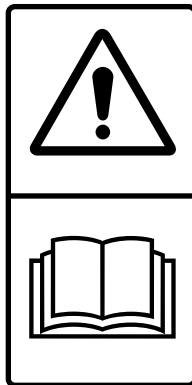

3. Warning!

Pinch point / crushing danger! Keep your hands away from all moving parts during and after split operation! Never try to clear a jammed log with your hands! Wait for all moving parts to come to a complete stop before loading or clearing obstructions.



4. Warning!

Keep feet away from falling split wood. Always wear steel toed foot wear while machine is operating to avoid serious personal injury.

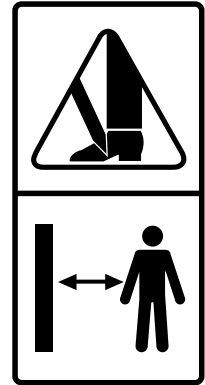

IMPORTANT! If parts are replaced that have safety signs on them, new signs must be applied. Safety signs must always be replaced if they become damaged, are removed, or become illegible.

Safety signs are included in the product decal kit available from your authorized dealer. Decals are not available separately.

3.2.1 Replacing Damaged Safety Signs

- Always keep safety signs clean and legible.
- Replace safety signs that are missing or have become illegible.
- Parts that were replaced with a safety decal on them must also have the safety sign replaced.
- Replacement safety signs are available from your authorized Distributor, Dealer Parts Department, or Wallenstein Equipment.

Procedure

1. Be sure that the installation area is clean and dry.
2. Be sure temperature is above 50 °F (10 °C).
3. Determine exact position before removing from the backing paper.
4. Pull the decal off the backing sheet, align the sign over the specified area, then carefully press the exposed sticky backing in place.
5. Use a piece of the backing paper to smooth the decal out, pressing from the center outwards.
6. Small air pockets can be pierced with a pin and smoothed out using the piece of sign backing paper.

4. Familiarization

4.1 To the New Operator

It is the responsibility of the owner or operator to read this manual and to train all other operators before they start working with the machine. Follow all safety instructions exactly.

By following recommended procedures, a safe working environment is provided for the operator, bystanders and the area around the work site. Untrained operators are not qualified to use the machine.

Many features incorporated into this machine are the result of suggestions made by customers like you. Read this manual carefully to learn how to use the machine safely and provide maximum operating efficiency. By following the instructions in conjunction with a good maintenance program, your wood splitter can provide many years of trouble-free service.

IMPORTANT! Make sure all operators understand how to put the wood splitter in a Safe Condition before working with this machine. See Safe Condition *page 10*.

4.1.1 Training

Each operator must be trained in the proper set-up and operating procedures before using the machine.

1. Move the unit to a large open area to allow the operator to become familiar with control functions and machine response.
2. Do not allow untrained operators to use the machine. They can endanger themselves and others, or damage property and the machine.

4.1.2 Job Site Familiarization

It is the responsibility of the operator to be thoroughly familiar with the work site prior to starting.

1. Check for close or cramped work space. Be sure there is sufficient space and clearance for the machine to operate.
2. Organize the working area to minimize movement.
3. Position the machine so prevailing winds blow engine exhaust fumes away from operator's station.

4.2 Machine Components

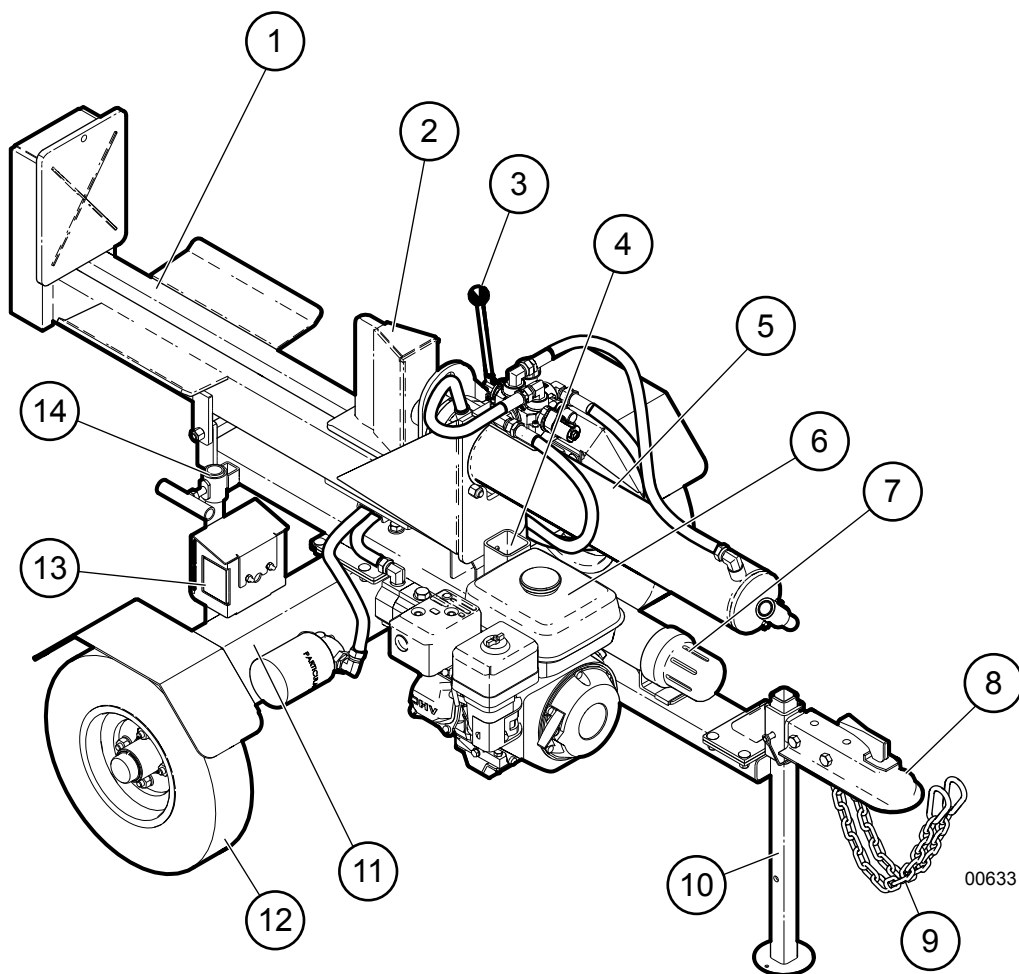

Fig. 3–WX540, WX540L Wood Splitter Components

1. Tilting Splitter Bed
2. Sliding Wedge
3. Splitter Control Valve Handle
4. Splitter Bed Spring Latch
5. Hydraulic Cylinder
6. Honda GX200 Engine
7. Product Manual Storage Tube
8. Trailer Tongue
9. Safety Chains
10. Front Jack Stand
11. Hydraulic Oil Reservoir
12. 4.80-8 LRB SportTrail Tire
13. Stop, Tail, Turn Signal Lights (WX540L only)
14. Rear Jack Stand

5. Controls

IMPORTANT! Before starting work with the wood splitter, become familiar with the location and function of all controls.

5.1 Engine

Refer to the engine manual that came with this product for further explanation on engine controls.

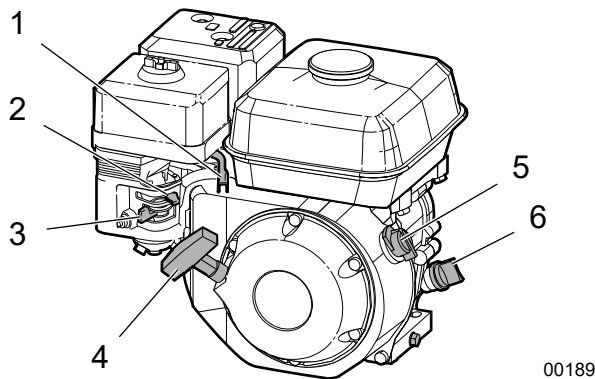

Fig. 4—Engine Controls

1. Throttle Lever
2. Fuel Valve Lever
3. Choke Lever
4. Starting Rope
5. Ignition Switch
6. Oil Level Check

5.1.1 Ignition Switch

This rotary switch controls the ignition system.

- The engine operates in the ON position. Before starting the engine, turn the switch to ON.
- Turn it counter-clockwise to OFF to stop the engine.

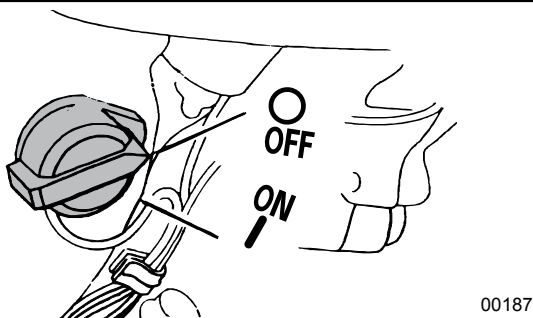

Fig. 5—Ignition Switch

5.1.2 Choke Lever

The choke lever opens and closes the choke valve in the carburetor.

- Place the choke lever in the CLOSED position (3) when starting a cold engine.
- Move the choke lever to the OPEN position (2) after the engine starts. When restarting a warm engine, leave the lever in the OPEN position.

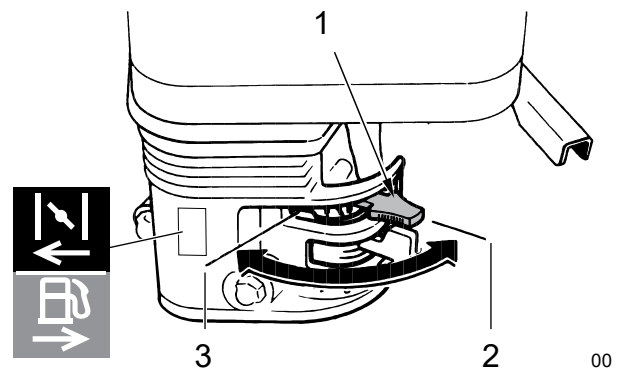

Fig. 6—Choke Lever

1. Choke Lever
2. Choke Open Position
3. Choke Closed Position

5.1.3 Fuel Shut-off Valve

The engine is equipped with a valve between the fuel tank and the carburetor.

- Slide the fuel valve lever toward the block (2) to turn fuel ON, and away (3) to turn OFF.
- Turn the fuel OFF when not in use or when transporting.

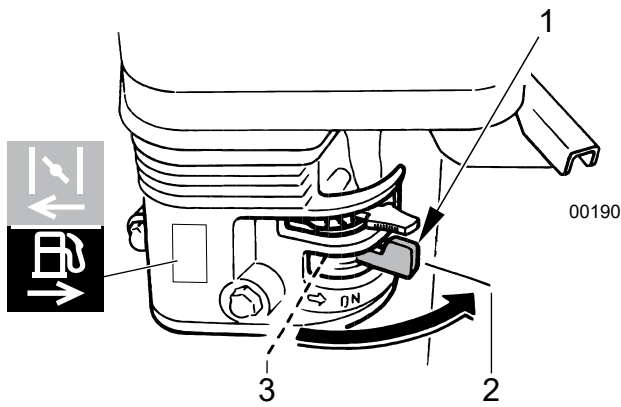

Fig. 7—Fuel Valve Lever

1. Fuel Shut-off Valve Lever
2. ON Position
3. OFF Position

5.1.4 Throttle Lever

This lever controls the engine speed. Move the lever side to side to increase or decrease engine rpm. Always operate the wood splitter with the throttle lever in the MAX position.

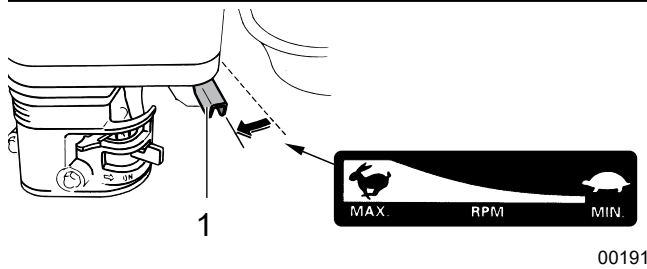

Fig. 8—Throttle Lever Positions

1. Throttle Lever

5.1.5 Recoil Starter

The recoil starter is located on the side of the engine. The starter grip is pulled out by hand to start the engine.

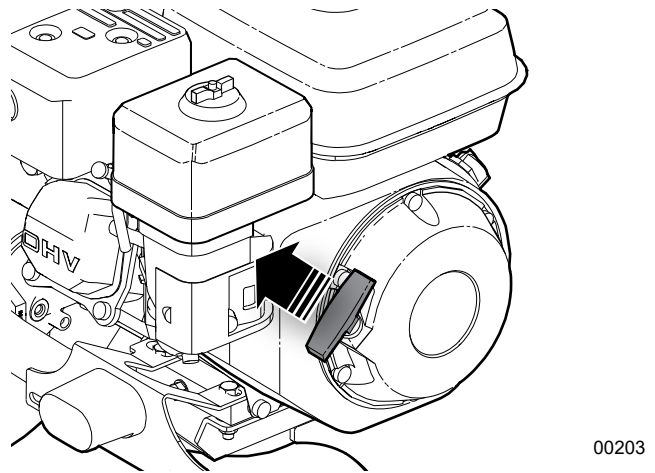

Fig. 9—Recoil Starter

5.2 Hydraulic Valve

The control valve extends and retracts the wedge to split the wood. The lever on the valve has three positions—Extend, Neutral, and Retract.

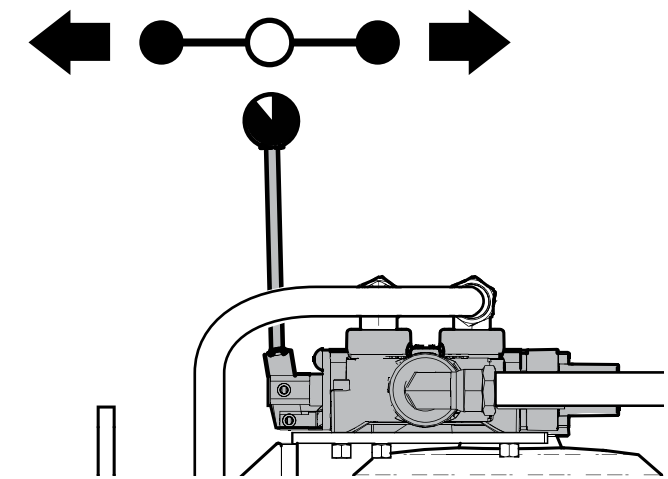

Fig. 10—Splitter Control Valve

1. Push the lever forward (toward the wood) and hold to extend the wedge and split the wood.
2. Pull the lever fully back to retract the wedge. When retracting, a detent holds the lever until the wedge / push block fully returns, providing hands-free operation.
3. Once the wedge is fully retracted, the lever spring-returns to neutral.

Neutral Position

- Neutral is the center position on the valve.
- The wedge stops moving when the valve lever is moved to Neutral.
- The valve lever can be moved to Neutral from Extend or Retract at any time.

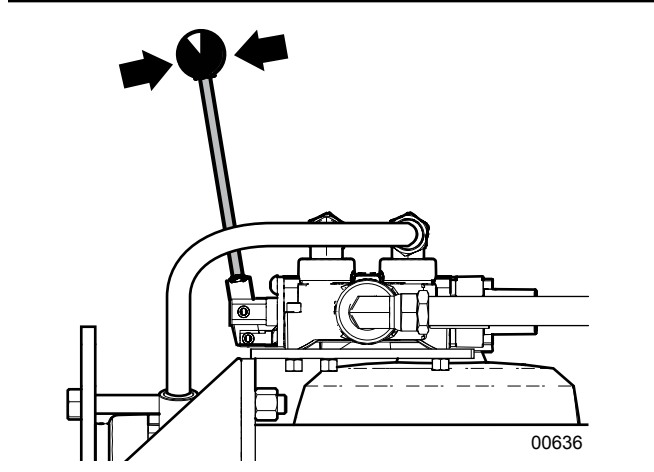

Fig. 11—Center (Neutral) Position

Extend

- Push the lever forward (toward the wood) and hold to extend the wedge and split the wood.
- Releasing the lever returns it to Neutral.

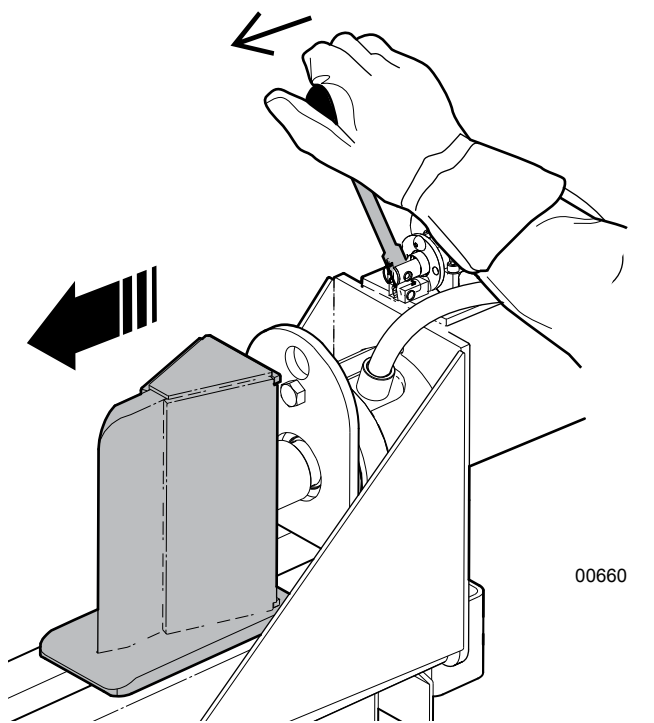

Fig. 12—Extend Wedge to split Wood

Retract

- Pull the lever fully backwards to retract the push block. The valve detent holds the lever in Retract allowing a hands-free return cycle.
- The valve lever spring-returns to Neutral when released from auto-retract.

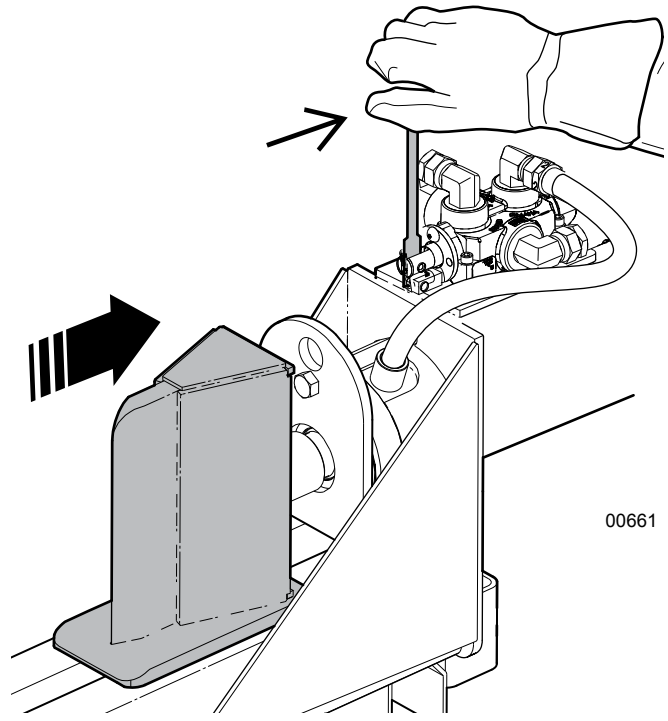

Fig. 13—Retract Wedge

5.3 Stroke Limiter Accessory

The Stroke Limiter accessory improves productivity when splitting shorter pieces. It stops the cylinder from fully returning to the home position.

5.3.1 Stroke Limiter Adjustment

1. Place a typical sized log on the splitter bed, then start / apply power to the wood splitter.
2. Using the hydraulic control, move the anvil or wedge up to the log, but stop approximately 3" (8 cm) from it.
3. Shut off the engine. Make sure the hydraulic control lever is in the neutral position.
4. Loosen the hex set screw on the rod adjusting collar, and move the rod up to the anvil / wedge. (This is the set position at which the anvil or wedge stops on the return cycle.) Tighten the hex screw.
5. Test the set up by cycling the anvil / wedge through its path. Split a log then put the hydraulic lever into the return (detent) position. The lever should trip the hydraulic control and the anvil / ram stops at the set position. Adjust as required.

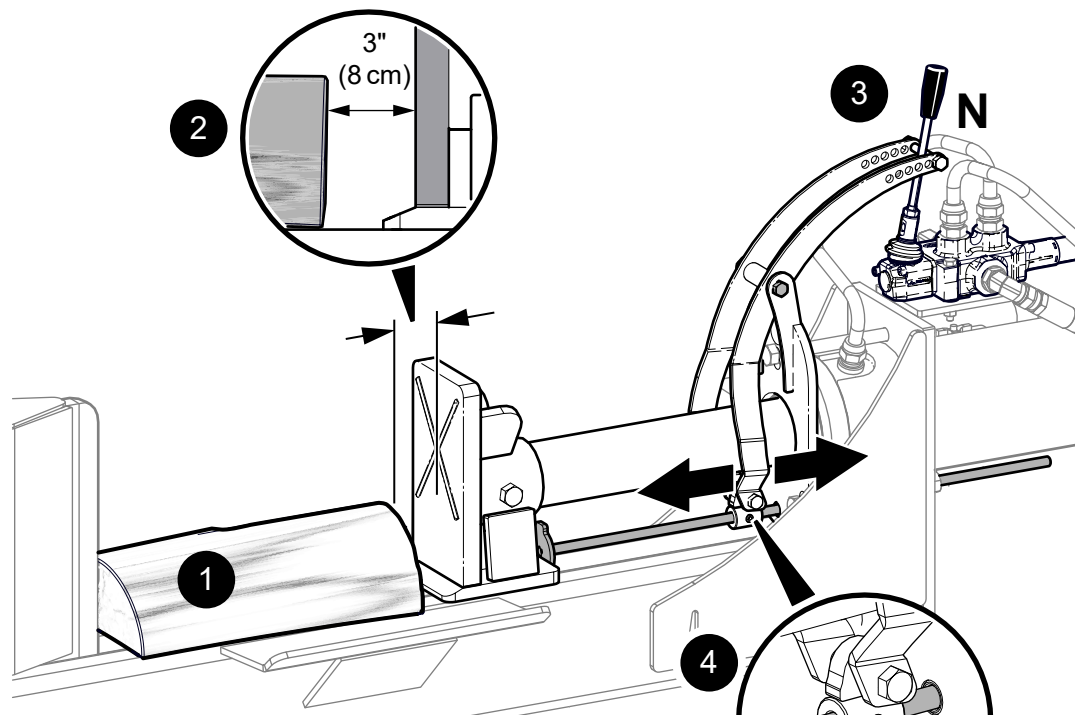

Fig. 14—Splitter Stroke Limiter

6. Operating Instructions

The operator has the responsibility of being familiar with all operating and safety procedures and following them.

6.1 Operating Safety

Read and obey the safety signs on the machine. Clean or replace them if they are not legible.

There is no substitute for a cautious, safe-minded operator who recognizes potential hazards and follows reasonable safety practices. This machine must be used with all its safety equipment properly installed to minimize the chance of accidents.

1. Wear appropriate personal protective equipment. Tie back long hair, remove jewelry, and avoid loose fitting clothing. Prolonged exposure to loud noise can cause permanent hearing loss! Wear hearing protection on a full-time basis when using this machine.
2. The operator must be in control of the machine at all times. Read and understand owner's manual before starting. Review safety instructions annually.
3. Never use engine-powered machinery indoors. Gas engine exhaust contains toxic carbon monoxide, which cannot be smelled or seen. Breathing carbon monoxide can be lethal.
4. Make sure all guards, deflectors and shields are in place before starting and operating.
5. Keep hands out of splitting area. Do not rest hands on the log being split.
6. Do not step over or straddle splitter during operation.
7. Do not try to split more than one log at a time. The logs can fly out and cause injury.
8. Keep your fingers and hands away from cracks in the log that can open while splitting.
9. Always load logs by grasping the bark side, not the cut ends.
10. Do not reach into or load the splitter when the wedge is in motion.
11. Do not try to split logs across the grain. Some types of wood can burst or splinter causing pieces to be thrown causing injury.
12. For uneven cut logs, always place the squares cut end against the splitting wedge.
13. Never place any part of your body where it would be in danger if machine movement should occur during assembly, installation, operation, maintenance, repairing or moving.
14. Before servicing or repairing the machine, place it in a **Safe Condition**. See *page 10*.

6.2 Before Starting the Engine

1. Check the engine oil level. See *page 24*.
2. Check the hydraulic oil level. See *page 24*.
3. Check the fuel level.
4. Check the engine air cleaner. See *page 36*.
5. Clear the area of bystanders, especially small children.
6. Make sure each operator is trained and familiar with the set up and operation of the wood splitter.
7. Follow the Pre-Operation Checklist.
8. Review the Controls section (see *page 18*).
9. Survey the work site and position the wood splitter in a clear, level work area.
10. Set up the machine correctly. See *Machine Set-up on page 25*.

6.3 Pre-operation Checklist

Efficient and safe operation of the Wallenstein wood splitter requires that each operator reads and understands the operating procedures and all related safety precautions outlined in this section.

A Pre-operation Checklist is provided for the operator. The checklist is important for both personal safety and keeping the wood splitter in good mechanical condition.

Before operating the machine and each time thereafter, the following areas should be checked off:

Pre-operation Checklist	✓
Check engine oil level. Top level up as required.	
Check hydraulic fluid level. Top level up as required.	
Check and lubricate the machine following the schedule outlined in the Maintenance section.	
Check the wedge and block. Be sure they are not damaged or broken and is not badly worn. Repair or replace as required.	
Check and remove any entangled material.	
Check for hydraulic leaks. Tighten connections or replace components to stop leaks.	
Check and ensure that all covers, guards and shields are in place, secured, and can function as designed.	
Check and inspect tires, wheels, and hubs.	
Check and tighten all fasteners. Make sure the equipment is in good condition.	
Check that appropriate equipment for personal protection is being used and in good condition.	
Check that jewelry, loose-fitting clothing are not worn. Make sure long hair is tied back.	

6.4 Machine Break-In

Although there are no operational restrictions on the wood splitter when used for the first time, it is recommended that the following items be checked:

Review the engine owner's manual for break-in recommendations. Place the machine in a **Safe Condition** before checking any components. Refer to *Safe Condition on page 10*.

After 1 hour of operation

1. Check that the push block or wedge is adequately lubricated.
2. Check all nuts, bolts and other fasteners. Tighten to their specified torque level.
3. Check hydraulic system for leaks. Tighten all leaking fittings and replace any leaking components.
4. Check machine fluid levels—Fuel, engine oil, and hydraulic oil reservoir. Top up as required.
5. Check for entangled material. Remove all entangled material before resuming work.
6. Check tire pressure. Inflate as required.

After 8 hours of operation

7. Repeat the above steps.

6.5 Engine Oil Level Check

Check engine oil level daily.

Check with the machine parked on level ground and the engine stopped.

IMPORTANT! Running the engine with a low oil level can cause engine damage that is not covered by warranty.

1. Remove the oil level dipstick and wipe it clean.
2. Fully insert the oil level dipstick, then remove it to check the oil level. **The proper level is when the oil is visible at the full (upper) mark on the dipstick.**
3. If the oil level is low, add oil until the level is at the full mark. **SAE 10W-30 is recommended for general use.**
4. Reinstall the oil level dipstick.

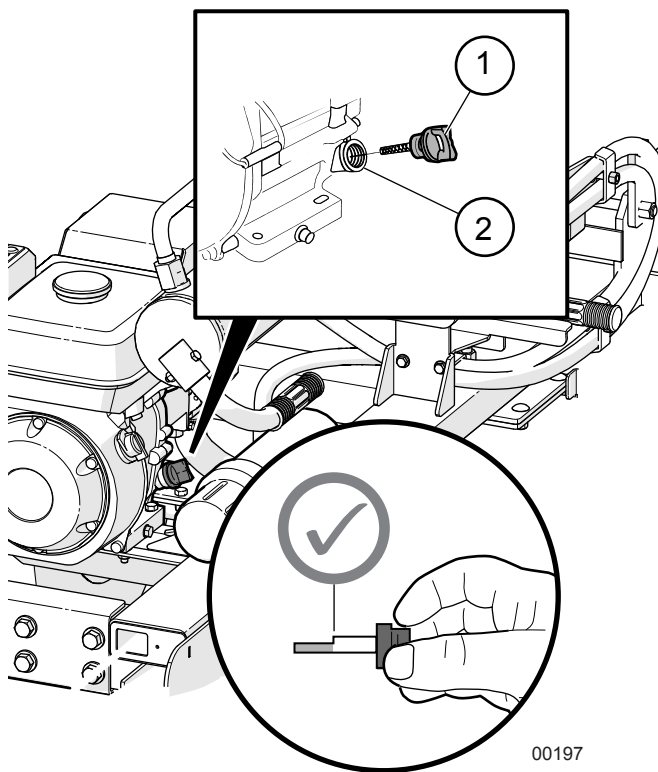

Fig. 15—Engine Oil Level check

1. Oil Level Dipstick
2. Oil Filler

Refer to the engine owner's manual included in the manual tube for further information on engine oils.

6.6 Hydraulic Oil Level Check

Check hydraulic oil level every 40 hours or weekly.

Check with the machine parked on level ground and the engine stopped.

The proper level is when the oil is visible at the full (upper) mark on the dipstick.

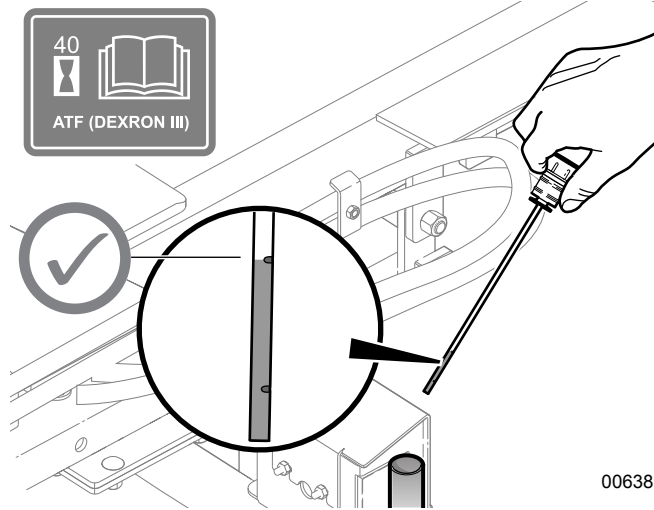

Fig. 16—Hydraulic Tank Oil Level Dipstick

IMPORTANT! Do not operate machine if oil level is not visible on the dipstick. Damage to the pump and other components can occur.

Do not overfill the tank past the full mark.

Always check oil levels after changing filters or servicing hydraulic components.

Hydraulic oil quality should be inspected every 40 hours. If the oil is dirty or smells burnt, it should be replaced.

Be aware of high oil temperatures. Temperatures higher than 180 °F (82 °C) could cause seal damage and degrade oil quality.

6.6.1 Hydraulic Oil – Adding

The hydraulic system uses **Dexron® III ATF**.

1. Clean the area around filler cap and remove it.
2. Use a clean funnel and add oil until the level is at the full mark on the dipstick.
3. Install filler cap securely. Wipe up any spilled oil.

6.7 Fuel Level Check

Check the fuel level daily.

Starting with a full tank helps to eliminate or reduce operating interruptions for refueling.

The fuel tank is located on the engine. Avoid running the tank dry.

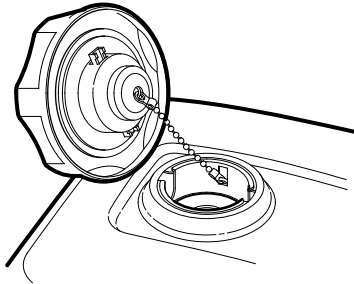

Fig. 17—Fuel Filler Cap

6.7.1 Refueling

Fuel tank capacity: **0.95 US gal (3.6 L).**

WARNING!



Fuel vapors can explode causing injury or death. Do not smoke while refueling. Keep sparks, flames, and hot components away.

W027

Refuel in a well-ventilated area with the engine stopped. If the engine has been running, allow it to cool first. Never refuel the engine inside a building where gasoline fumes can come in contact with flames or sparks.

For fuel specification, see *Fluids and Lubricants* on page 32. Refer to the engine manual for additional information on fuels.

1. Clean the area around fuel tank cap. **Fill the tank to 1/2" (12 mm) below bottom of filler neck to provide space for any fuel expansion.** Do not overfill.
2. Install fuel fill cap securely and wipe up any spilled fuel.

6.8 Machine Set-up

IMPORTANT! Park the wood splitter on a level, dry work area free of debris and other objects.

Position the splitter so the prevailing wind blows engine exhaust away from the operator.



If a tow vehicle is available, leaving the splitter attached to it provides greater stability.

WX540 splitters are designed with a pivoting main frame that allows horizontal or fully vertical splitting.

1. Position the splitter next to the wood to be split.
2. Leave the splitter attached to the tow vehicle. If no tow vehicle is available, lower the front crank jack and the rear jack stand. Chock the wheels so the machine is stable.
3. Make sure working area is clear of stones, branches or other obstacles.
4. Pre-cut logs to desired block size, ready to load onto splitter bed.
5. Determine where the split wood is going to be piled. Make sure that location does not interfere loading splitter.

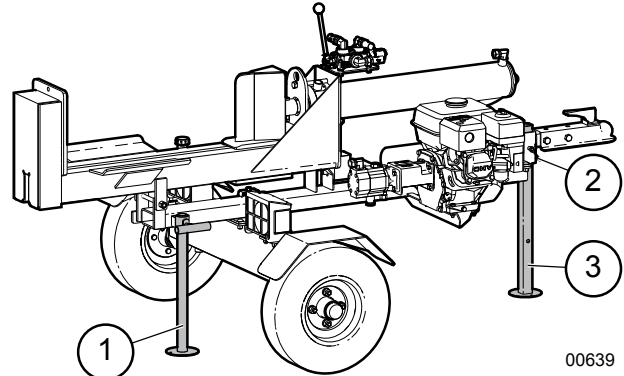

Fig. 18—WX540, WX540L Set-up

1. Rear Jack Stand
2. Front Jack Stand
3. Snap Lock Pin

6.9 Starting the Engine

CAUTION!

Before starting engine, review the operating and maintenance instructions in the engine manual.

W019

CAUTION!



Hearing loss hazard. Prolonged exposure to loud noise may cause permanent hearing loss. Use suitable protection while operating the machine.

W016

Make sure the wood splitter is set up to work and otherwise ready to run.

1. If the engine is cold, close the choke (push choke lever to the left). To start a warm engine, leave the choke open (lever pushed to the right).

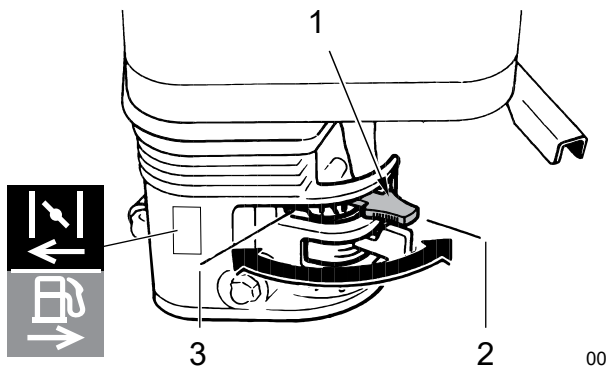
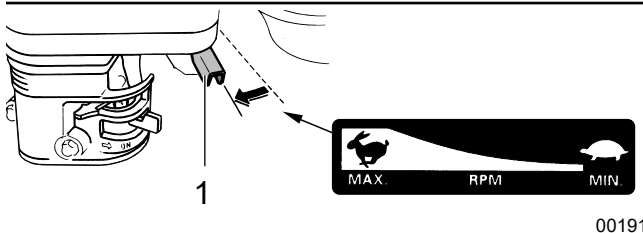

Fig. 19–Choke Lever

1. Choke Lever
2. Choke OPEN
3. Choke CLOSED

2. Move the throttle lever away from the MIN. position, about 1/3 of the way toward the MAX position.



00191

Fig. 20–Engine Throttle

1. Throttle Lever

3. Turn the engine ignition switch ON.

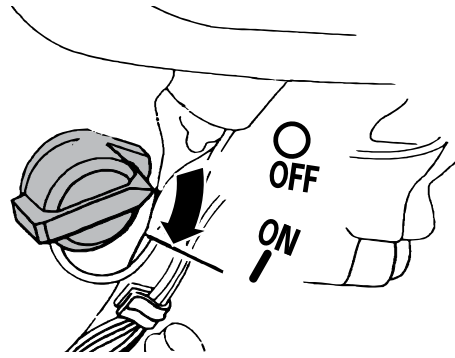

00705

Fig. 21–Ignition Switch

4. Pull the starter grip out lightly until resistance is felt, then pull briskly in the direction of the arrow as shown below. Return the starter grip gently.

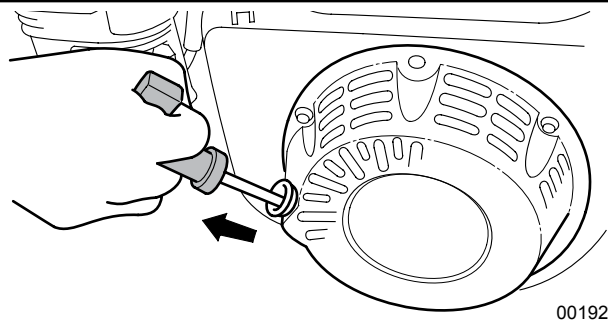

00192

Fig. 22–Recoil Starter

IMPORTANT! Do not allow the starter grip to snap back against the engine. Return it gently to prevent damage to the starter.

5. Leave the engine operating at low throttle for a few minutes to allow it to warm up. Gradually push the choke control lever open (to the left) as the engine warms.

IMPORTANT! Engine should be warmed up before putting to work.

6. Once the engine is warmed, increase the throttle setting to MAX before beginning.

6.10 Stopping the Engine

To stop the engine in an emergency, turn the ignition switch OFF. Correct fault situation before restarting.

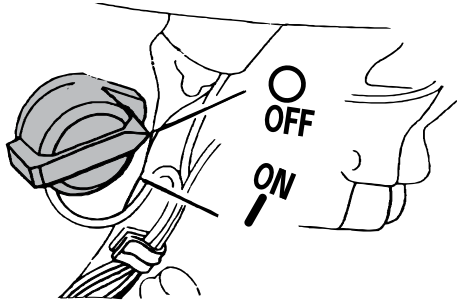

00187

Fig. 23—Ignition Switch

Under normal conditions, use the following procedure

1. Stop loading material onto the splitter bed.
2. Decrease engine speed to MIN.
3. Turn the ignition switch OFF.

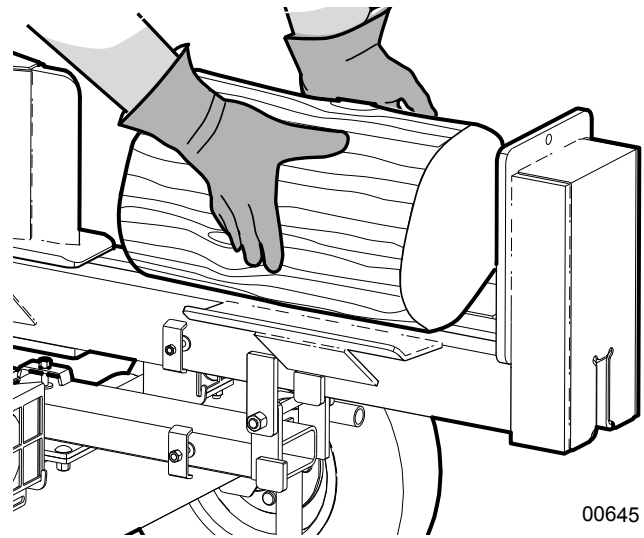

00645

Fig. 24—Correct Log Placement—Horizontal

6.11 Log Placement

WARNING!

Risk of pinching or crushing hazard between the wedge or push block and the log!

Never place hands at the ends of the log.
Always grasp logs by the sides when loading or removing.

W035

- Always grasp the log by the sides not the ends when placing in or removing logs from the splitter. This minimizes the chance of the operator getting fingers, hands or arm between the wedge / push block and the log.
- Any logs or debris remaining on the splitter bed should only be removed after it is safe to do so.

6.12 Splitting Wood

WARNING!

Risk of pinching or crushing hazard! The worker loading the splitter **MUST** be the only one in control of the hydraulic cylinder and splitting wedge.

Only one worker should operate and load the wood splitter.

W036

6.12.1 Horizontal Splitting

1. Place wood or log on the splitter.
2. Push control lever forward and hold to split wood.
3. Release the lever when the log splits or cylinder reaches full stroke and stops.
4. Pull the lever back to retract the push block or wedge. The detent holds the lever until the cylinder fully retracts, allowing hands-free operation.

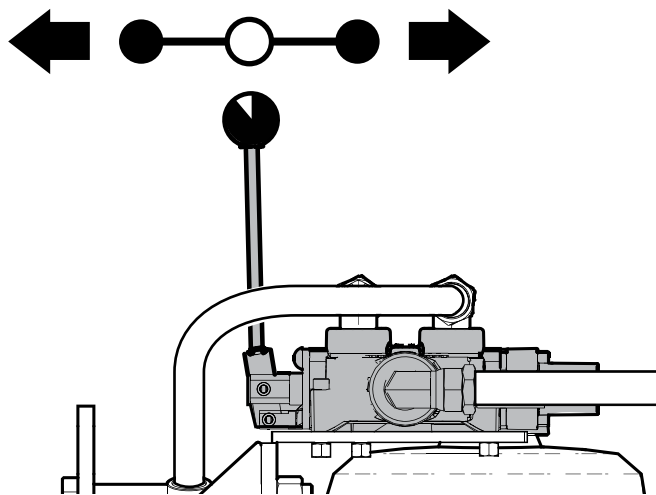

Fig. 25—Hydraulic Control Valve Positions

IMPORTANT! Do not hold the valve lever to extend or retract the cylinder once it has reached the end of its stroke. Doing so can overheat the oil and could damage the engine.

5. If the log is large enough to require another split, reposition and repeat steps.

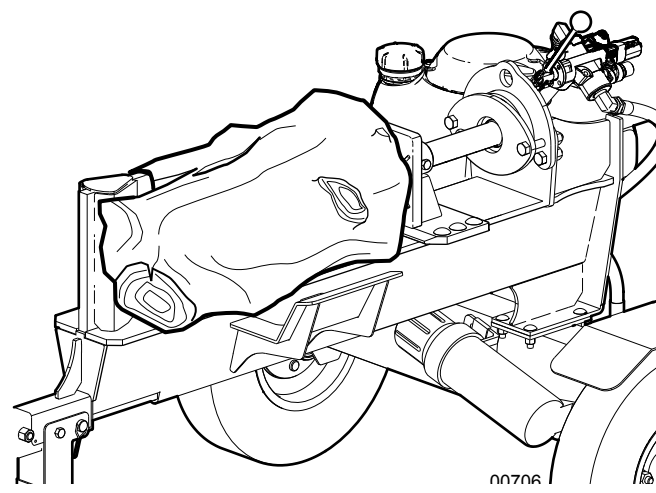

Fig. 26—Single Blade Wedge

6. Pile the split wood close to the working area, but do not allow pieces to pile up and clutter the area. A cluttered working area can lead to tripping and an accident.

6.13 Vertical Splitting

1. Before tilting the splitter frame, lower the rear jack stand. Loosen the handle counter-clockwise, lower the stabilizer and tighten the turn handle.

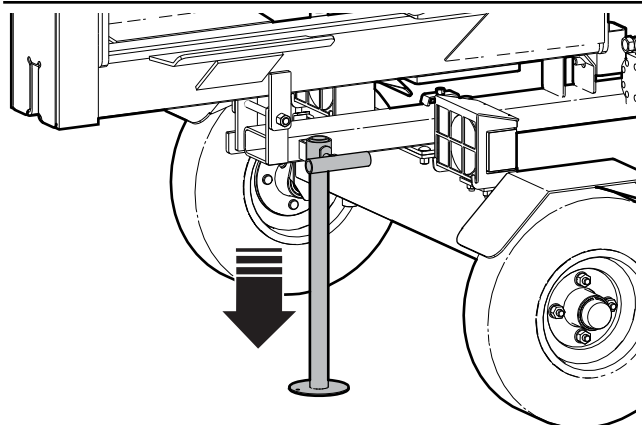

Fig. 27—Rear Jack Stand

2. While standing beside the controls, release the splitter beam by pulling the spring-loaded frame latch outward.
3. At the same time, grab the cylinder end and tip the splitter beam assembly up towards the vertical position.

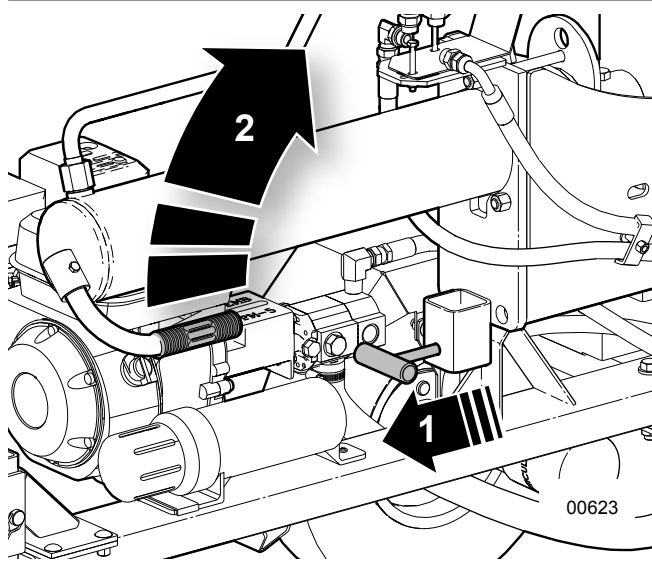
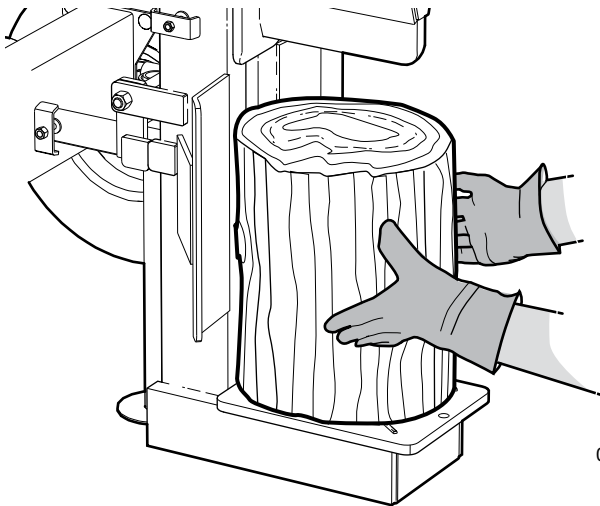

Fig. 28—Rotate Splitter to Vertical

4. Continue tipping, while placing your foot on the hydraulic tank / axle as a brace, until splitter is in the full vertical position.
5. Set the log or block onto the splitter base.



00645

Fig. 29—Correct Log Placement—Vertical

! WARNING!

Risk of pinching or crushing hazard! The worker loading the splitter **MUST** be the only one in control of the hydraulic cylinder and splitting wedge.

Only one worker should operate and load the wood splitter.

W036

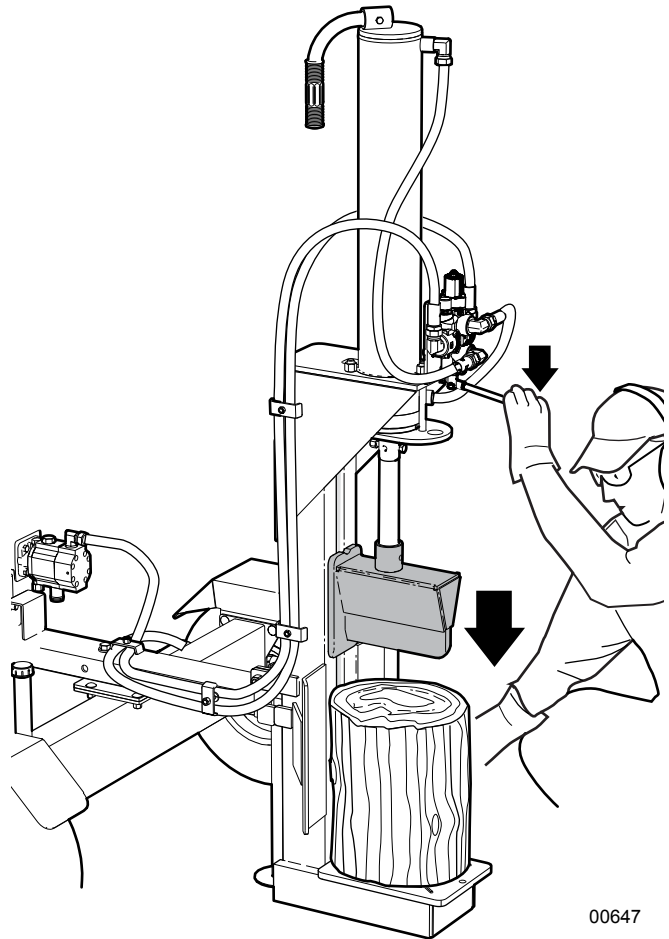

00647

Fig. 30—Vertical Splitting

6.14 Transporting

6.14.1 Transport Safety

1. Comply with local laws governing safety and transporting of machinery on public roads.
2. Do not exceed 50 mph (80 km/h) when towing this machine. Slow down for rough terrain and cornering.
3. Do not transport or move the wood splitter with the engine running.
4. Be sure the trailer is hitched correctly to the towing vehicle and a retainer is used through the hitch mechanism.
5. Always attach safety chains between the hitch and the towing vehicle. Cross the chains underneath the trailer tongue.
6. Check wheel lugs and tighten if required. Inspect rims for damage.
7. Inspect tires for cuts or damage. Check tire pressure and adjust if required.

8. Ensure the stability jacks are raised and secured with the latch pin.
9. Make sure tow vehicle is fitted with the correct size (2 in) towing ball.
10. Make sure fuel and hydraulic tank caps are on tight to prevent spills while transporting.
11. Clean all debris off the splitter. Remove any tools or other loose items.
12. Check that all the lights, reflectors and other lighting requirements are installed and in good working condition.
13. Never allow riders on the machine.
14. Be a safe and courteous driver. Always yield to oncoming traffic in all situations, including narrow bridges, intersections, and so on.
15. Watch for other traffic when near or crossing roadways.
16. Do not drink and drive.
17. Before transporting, perform a walk-around inspection to ensure everything is safe.

6.14.2 Prepare for Transport

- Make sure the pivoting main frame is fully lowered to horizontal. The lock pin in the pivoting splitter beam must be fully engaged.

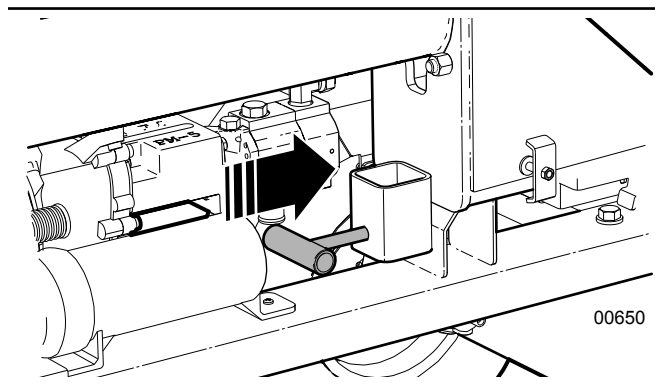

Fig. 31—Lock Pin Fully Engaged

- Turn the fuel OFF when transporting.

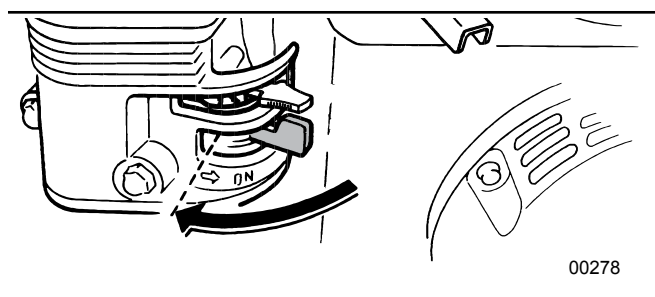

Fig. 32—Fuel Valve OFF

- Clean all debris from the splitter that could fall off in transport.

- Check tire pressure. Inspect for cuts or damaged rims.
- Check lug nuts and re-torque as necessary. Inspect again after 20–25 mi (32–40 km). Check weekly. See *page 40*.
- Inspect and replace any axle dust caps that are missing, damaged or leaking.
- Always be in compliance with all applicable local regulations when transporting.

6.15 Connecting a Tow Vehicle

1. Keep bystanders are clear of the machine.
2. Make sure there is enough room and clearance to safely back up to the machine.
3. Slowly back the tow vehicle until the coupler on the hitch and ball are aligned.

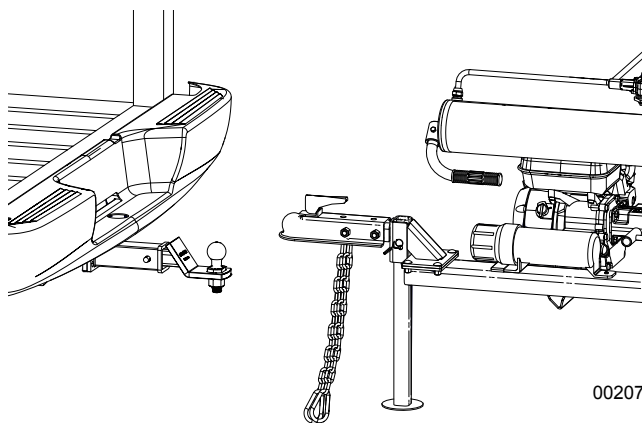

Fig. 33—Ball Hitch Aligned

4. Lift the hitch and place the coupler over the ball on the hitch.
5. Flip the latch to lock the coupler around the ball.
6. Pull out the jack stand snap lock pin and raise the jack stand to its stowed position. Install snap lock pin to secure it.
7. Raise the rear jack stand and secure with the snap lock pin.
8. Cross safety chains under trailer tongue and attach securely to the tow vehicle hitch.
9. Connect the wiring harness for the lights (as equipped).
10. Reverse the above procedure when unhooking.

6.16 Storing the Wood Splitter

After the season's use and the wood splitter is going to be put away in storage, it should be thoroughly inspected and prepared. Repair or replace any worn or damaged components to prevent any unnecessary down time at the start of next season. The wood splitter can have a long, trouble-free life by following these steps:

IMPORTANT! Refer to the engine manufacturer's manual for information specific to engine storage.

1. Fully retract the cylinder ram.
2. Add a stabilizer to the fuel tank. Top up the tank and run the engine outdoors for 10 minutes to be sure that treated gasoline has replaced the untreated gasoline in the carburetor.
3. Turn fuel valve OFF.
4. Thoroughly wash the machine using a pressure washer to remove all dirt, mud, debris, and residue.
5. Inspect the wedge, cylinder ram, push block and wear plates for damage or entangled material. Repair or replace damaged parts. Remove all entangled material.
6. Touch up all paint nicks and scratches to prevent rusting.
7. If the splitter is to be stored for longer periods (over 6 months), follow the engine manufacturers recommendations for storage preparation.
8. Store the machine in an area away from human activity.
9. Select an area that is dry, level and free of debris to park the wood splitter.
10. If the wood splitter is not stored inside a building, cover with a waterproof tarp. Tie securely in place.
11. Do not allow children to play on or around the stored machine.

6.17 Removing from Storage

1. Review and follow the Pre-operation Checklist. See *page 35*
2. Review safety and operation procedures. See *page 9*.

7. Service and Maintenance

WARNING!

Risk of serious personal injury. Stop engine before performing ANY service or maintenance procedure. Reinstall all covers and shields removed before putting machine back into service.

W033

IMPORTANT! Refer to the engine manufacturer's manual for engine maintenance and service information.

7.1 Maintenance Safety

1. Follow good shop practices:

- Keep service area clean and dry.
- Be sure electrical outlets and tools are properly grounded.
- Use adequate light for the job at hand.



2. Never operate the machine or the towing vehicle in a closed building. The exhaust fumes may cause asphyxiation.
3. Before servicing or repairing, place the machine in a **Safe Condition**. See *page 10*.
4. Allow the engine to cool before performing maintenance. Engine components and oil may be hot enough to cause injury.
5. Never work under equipment unless it is properly supported.
6. When performing any service or maintenance work always use personal protective equipment.
7. Where replacement parts are necessary, use only OEM parts to restore your equipment to original specifications. The manufacturer is not responsible for injuries or damages caused by use of unapproved parts or accessories.
8. Inspect and tighten all bolts, nuts and screws. Check that all electrical and fuel connections are properly secured.
9. When completing a maintenance or service function, make sure all safety shields and devices are installed before placing splitter in service.
10. When cleaning any parts, do not use gasoline. Use a cleanser designed for that purpose.

11. Always use proper tools in good condition. Make sure you understand how to use them, before performing any service work.

7.2 Fluids and Lubricants

1. Engine Oil

SAE 10W-30 motor oil is recommended for general use. Refer to the engine manufacturer's manual for maintenance and service information.

2. Grease

Use an SAE multi-purpose high temperature grease with extreme pressure (EP) performance. Also acceptable is an SAE multipurpose lithium-based grease.

3. Engine Fuel

This engine is certified to operate on unleaded gasoline with a pump octane rating of 86 or higher (a research octane rating of 91 or higher).

4. Hydraulic Oil

Use Dexron® III Automatic Transmission Fluid (ATF). Dexron VI or Mercon® ATF are also acceptable substitutions.

5. Storing Lubricants

Your machine can operate at top efficiency only if clean lubricants are used. Use clean containers to handle all lubricants. Store them in an area protected from dust, moisture and other contaminants.

7.3 Maintenance Schedule

Perform maintenance procedures at time shown or hour interval, whichever comes first.

As Required	
Check the condition of all hydraulic lines, hoses and fittings. Replace any that are damaged.	
Remove any entangled material from splitter.	
Check that all fasteners are tight.	

Every 8 hours or Daily	
Check fuel level	See page 25
Check engine oil level.	See page 24

Every 40 hours or Annually	
Check hydraulic oil level.	See page 24
Clean engine air filter	See page 36
Inspect hydraulic oil quality	See page 24
Grease frame slide, hinges, pivot points	See page 33

Every 100 hours or Annually	
Grease axle bearings	See page 33
Change engine oil	See engine manual
Check tire pressure	See rating on tire sidewall
Change hydraulic oil and filter	See page 35
Change engine air filter	See page 35
Clean machine. Remove debris and entangled material.	—
Change fuel filter	See engine manual

7.4 Grease Points

Use a hand-held grease gun for all greasing. Pump one shot of grease per fitting.



Look for this decal on your machine. It indicates a grease point and the interval in hours.

- Wipe grease fitting with a clean cloth before greasing to avoid injecting dirt and grit.
- If fittings do not take grease, remove and clean them thoroughly. Replace grease fittings as necessary.

Location	Every 40 hours of operation or as required
1	Frame slide

Location	Every 100 hours of operation or annually
2	Axle bearings – 2 places

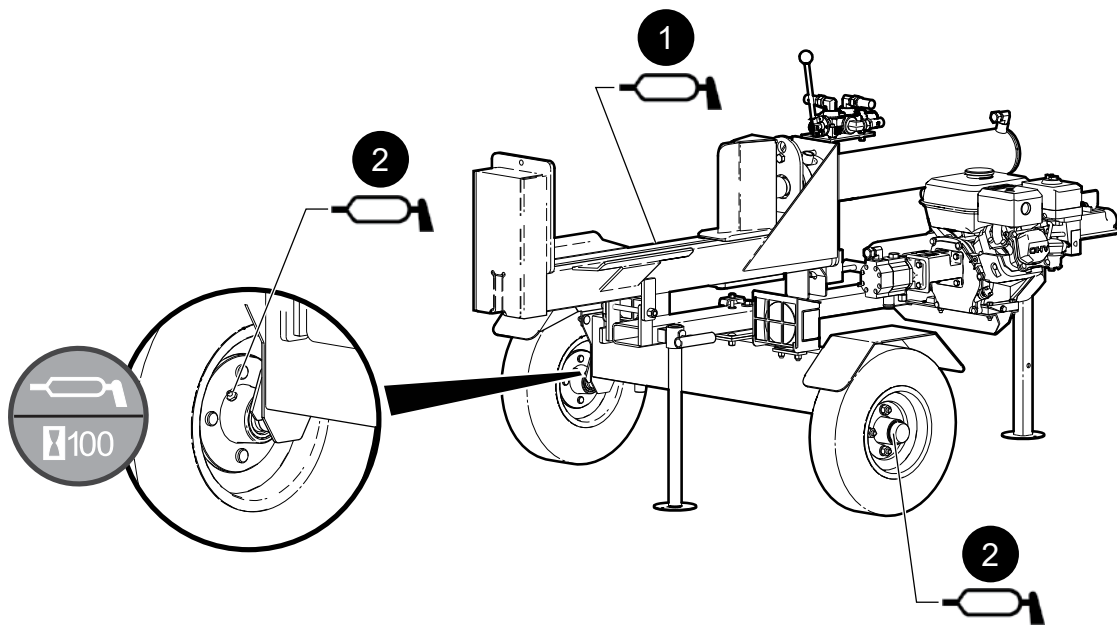

00662

Fig. 34 – Grease Points

7.5 Hydraulic Oil – Changing

Change the hydraulic oil at 100 hours of operation or annually.

- Hydraulic oil type: **Dexron® III ATF**
- Hydraulic reservoir volume: **1.8 US gal (7 L)**. An extra 1/2 gal (1–2 liters) may be required to top up the circuit.

CAUTION!



Risk of burns to exposed skin. Hydraulic oil becomes hot during operation. Hoses, lines, and other parts become hot as well. Wait for the oil and components to cool before starting any maintenance or inspection work.

W028

The hydraulic tank drain plug is located under the machine. A 3/8" Allen (hex) wrench is required to remove it.

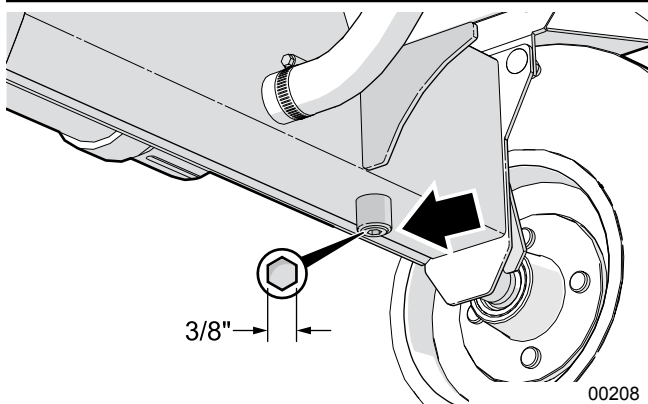

00208

Fig. 35–Hydraulic Tank Drain Plug

Procedure

1. Place a drain pan of suitable capacity under the drain plug.
2. Clean the area around drain and remove the drain plug.
3. Allow the oil to fully drain, then flush the tank.
4. Dispose of used oil in an environmentally safe manner.
5. Replace the plug and fill the tank with clean oil, up to the full mark on the dipstick.
6. Start the machine up and cycle hydraulic functions to purge air from the system.
7. Stop the engine and recheck the oil level. Top up to the full mark.

7.6 Hydraulic Oil Filter – Changing

Change hydraulic oil filter at 100 hours of operation or annually.

The filter is located on side of the hydraulic oil tank.

CAUTION!



Risk of burns to exposed skin. Hydraulic oil becomes hot during operation. Hoses, lines, and other parts become hot as well. Wait for the oil and components to cool before starting any maintenance or inspection work.

W028

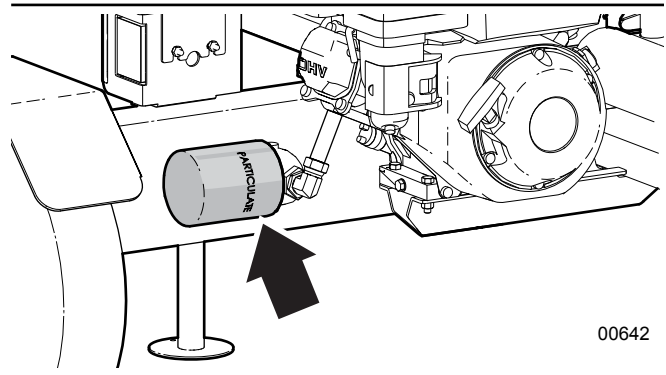

00642

Fig. 36–Hydraulic Oil filter

Procedure

1. Place a drain pan of suitable capacity under the filter head.
2. Remove the oil filter. An oil filter wrench may be required.
3. Apply a light coat of clean oil to the seal on the new filter and install it. Tighten by hand only.
4. Run the machine for 1–2 minutes operating the cylinder. Check filter head for oil leaks.
5. If a leak is found, shut off the machine and correct it.
6. Check hydraulic reservoir oil level. Top up as required.
7. Dispose of spilled oil in an environmentally safe manner.

7.7 Engine Air Cleaner

Check air filter every 40 hours of operation. Change air filter elements at 100 hours of operation or annually.

 **NOTE:** Refer to the engine manual for information on servicing the air cleaner.

A dirty air filter can restrict air flow to the carburetor, reducing engine performance. If the engine is operated in very dusty areas, clean the air filter more often than specified.

IMPORTANT! Operating the engine without an air filter, or with a damaged air filter, can allow dirt to enter the engine, causing rapid engine wear. This type of damage is not covered by Warranty.

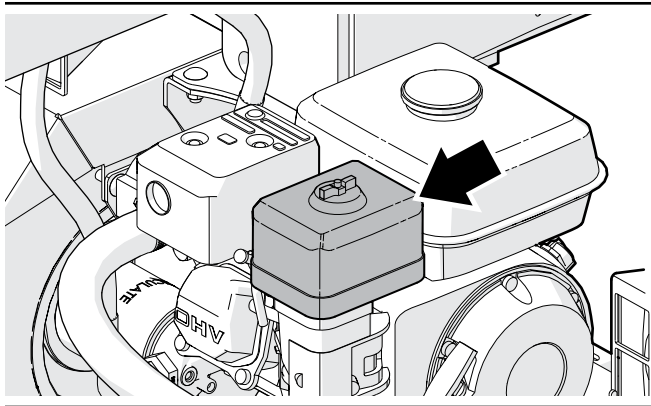
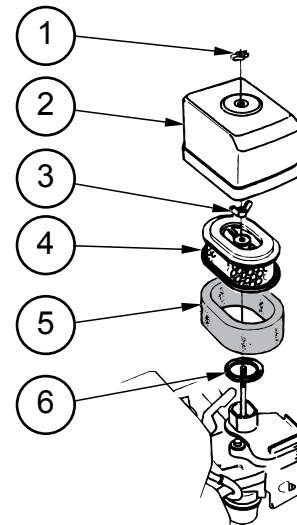

Fig. 37—Engine Air Cleaner

Inspection

Remove the air cleaner cover and inspect the filter elements. Clean or replace dirty filter elements. Always replace damaged filter elements.



00643

Fig. 38—Honda™ GX200 Air Cleaner

1. Wing nut
2. Air Cleaner Cover
3. Wing Nut
4. Paper Filter Element
5. Foam Filter Element
6. Gasket

7.8 Electrical System – General

(As equipped)

IMPORTANT! When assembling or replacing wire harnesses, apply a thin coating of silicone dielectric grease to the harness connectors.

Clean off any corrosion or loose particles, then apply a small amount to the surfaces of the connectors where they meet. The grease helps to stop any possibility of future corrosion.

Reassemble the connection. If grease squeezes out, wipe off with a rag or towel.

8. Troubleshooting

The following table lists some problems that may be encountered, with possible causes and solutions.

If a problem persists after reading through the Troubleshooting section, contact the local dealer, distributor or Wallenstein Equipment. Have the machine serial number ready.

Engine related issues

Refer to the Honda™ GX200 owner's manual found in the manual tube.

Problem	Cause	Solution
Cylinder rod moves slowly or does not move. Screeching or hissing noise.	No hydraulic oil pressure.	Oil filter plugged. Change filter.
		Low hydraulic oil level. Add oil.
		System relief pressure setting too low. Call technician.
	Wood jammed around wedge.	Shut machine off and safely remove wood.
Control handle does not go to neutral after rod is fully retracted.	Low engine speed.	Check throttle is set to maximum. Check that choke is off.
	Valve detent set too tight.	Adjustment required to detent on valve.
	Hydraulic oil too cold.	Allow machine to warm up.
Control handle goes to neutral before rod is fully retracted.	Hydraulic fluid is contaminated.	Change hydraulic fluid and filter.
Control handle does not go to neutral when released.	Detent set too loose.	Adjustment required to detent on valve.
Control handle does not go to neutral when released.	Control may be damaged.	Control may need service or be replaced. Call technician.
Cylinder stops on contact with wood.	Second stage on pump not functioning.	Pump may need to be serviced or replaced. Call technician.
Wedge or push block jumps.	Wedge or push block frame jamming.	Lubricate slider wear plates.
Leaking hydraulic hose.	Hose worn or damaged.	Replace hose.
Leaking cylinder.	Seals worn.	Seal replacement may be required. Call technician.

9. Specifications

9.1 Machine Specifications¹

Model	WX540, WX540L
Mounting	Trailer Mounted
Engine Model	Honda™ GX200; 6.5 hp (4.8 kW) @ 3,600 rpm
Engine Displacement	12 in ³ (196 cm ³)
Splitter Cylinder Bore x Stroke	4 x 24 in (10.2 x 61 cm)
Splitting Force	20 ton
Valve Type	Open Center – Auto-return Detent
Hydraulic Pump Type	2-stage, Gear
Hydraulic Pump Flow	11 gpm (47 Lpm)
Bed Height	24" (61 cm)
Wedge Height	9" (23 cm)
Tire Size	4.80 X 8
Tire Type	Highway
Safety Chains	Standard
Ball Hitch Size	2"
Splitter Orientation	Horizontal or Vertical
Average Cycle Time	6.62 seconds
Full Cycle Time	13.24 seconds
Weight	470 lb (213 kg)
Dimensions (L x W x H)	80 x 48 x 40"
	203 x 122 x 102 cm
Accessories	4-way Splitting Wedge
	All Weather Cover for Wood Splitter
	Stroke Limiter
	Clamp-on Shelf

¹ Specifications subject to change without notice.

9.2 Common Bolt Torque Values

Checking Bolt Torque

The tables shown give correct torque values for various bolts and capscrews. Tighten all bolts to the torque values specified in the table, unless indicated otherwise. Check tightness of bolts periodically.

IMPORTANT! If replacing hardware, use fasteners of the same grade.

IMPORTANT! Torque figures indicated in the table are for non-greased or non-oiled threads. Do not grease or oil threads unless indicated otherwise. When using a thread locker, increase torque values by 5%.

 **NOTE:** Bolt grades are identified by their head markings.

Imperial Bolt Torque Specifications						
Bolt Diameter	Torque Value					
	SAE Gr. 2		SAE Gr. 5		SAE Gr. 8	
	lbf•ft	N•m	lbf•ft	N•m	lbf•ft	N•m
1/4"	6	8	9	12	12	17
5/16"	10	13	19	25	27	36
3/8"	20	27	33	45	45	63
7/16"	30	41	53	72	75	100
1/2"	45	61	80	110	115	155
9/16"	60	95	115	155	165	220
5/8"	95	128	160	215	220	305
3/4"	165	225	290	390	400	540
7/8"	170	230	420	570	650	880
1"	225	345	630	850	970	1320



Metric Bolt Torque Specifications				
Bolt Diameter	Torque Value			
	Gr. 8.8		Gr. 10.9	
	lbf•ft	N•m	lbf•ft	N•m
M3	0.4	0.5	1.3	1.8
M4	2.2	3	3.3	4.5
M6	7	10	11	15
M8	18	25	26	35
M10	37	50	52	70
M12	66	90	92	125
M14	83	112	116	158
M16	166	225	229	310
M20	321	435	450	610
M30	1,103	1 495	1,550	2 100



9.3 Hydraulic Fitting Torque

Tightening Flare Type Tube Fittings

1. Check flare and flare seat for defects that might cause leakage.
2. Align tube with fitting before tightening.
3. Hand-tighten swivel nut until snug.
4. To prevent twisting the tube, use two wrenches. Place one wrench on the connector body and tighten the swivel nut with the second. Torque to values shown.

If a torque wrench is not available, use the FFFT (Flats From Finger Tight) method.

Hydraulic Fitting Torque					
Tube Size OD	Hex Size Across Flats	Torque value		Flats From Finger Tight	
		lbf•ft	N•m	Flats	Turns
3/16	7/16	6	8	2	1/6
1/4	9/16	11–12	15–17	2	1/6
5/16	5/8	14–16	19–22	2	1/6
3/8	11/16	20–22	27–30	1-1/4	1/6
1/2	7/8	44–48	59–65	1	1/6
5/8	1	50–58	68–79	1	1/6
3/4	1-1/4	79–88	107–119	1	1/8
1	1-5/8	117–125	158–170	1	1/8

Values shown are for non-lubricated connections.

9.4 Wheel Lug Torque

It is extremely important safety procedure to apply and maintain proper wheel mounting torque on your trailer axle. Torque wrenches are the best method to assure the proper amount of torque is being applied to a fastener.

Wheel lugs should be torqued before first road use and after each wheel removal. Check and re torque after the first 10 miles (16 km), 25 miles (40 km), and again at 50 miles (80 km). Check periodically thereafter.



WARNING!

Wheel lug nuts must be installed and kept at the proper torque value to prevent loose wheels, broken studs, or possible separation of wheels from axle.

- Start all lug nuts onto the threads by hand.
- Tighten lug nuts in stages, following the pattern shown in the Wheel Lug Nut Torque table.

Wheel Lug Nut Torque				
Wheel Size	Units	1st Stage	2nd Stage	3rd Stage
8"	lbf•ft N•m	12–20 16–26	30–35 39–45.5	45–55 58.5–71.5
12"	lbf•ft N•m	20–25 26–32.5	35–40 45.5–52	50–60 65–78
13"	lbf•ft N•m	20–25 26–32.5	35–40 45.5–52	50–60 65–78
14"	lbf•ft N•m	20–25 26–32.5	50–60 65–78	90–120 117–156
15"	lbf•ft N•m	20–25 26–32.5	50–60 65–78	90–120 117–156
16"	lbf•ft N•m	20–25 26–32.5	50–60 65–78	90–120 117–156

Wheel Lug Torque Pattern

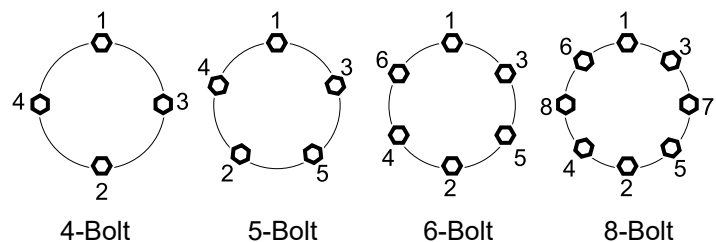

10. Alphabetical Index

A		I	
Air Cleaner Inspection.....	36	Ignition Switch.....	18
Angled Splitter Bed.....	26	Informative Labels.....	7
B		Introduction.....	2
Before Starting the Engine.....	22	Foreword.....	2
Bolt torque.....	39	L	
Break-in.....	23	Log Placement.....	27
C		Lubricants.....	32
Checking Bolt Torque.....	39	M	
Choke Lever.....	18	Machine Components.....	17
Connecting a Tow Vehicle.....	30	Machine Set-up.....	25
Controls.....	18	Machine Specifications.....	38
Control Valve.....	19	Maintenance Decals.....	7
Engine Controls.....	18	Maintenance hour interval.....	33
Stroke Limiter Accessory.....	21	Maintenance Schedule.....	33
Control Valve.....	19	O	
D		Operating Hints.....	27
Decal Information.....	7	Operating Instructions.....	22
Delivery Inspection Report.....	4	Before Starting the Engine.....	22
E		Engine Oil Level Check.....	24
Engine.....	32	Fuel Level Check.....	25
Engine Air Cleaner.....	36	Log Placement.....	27
Engine Controls.....	18	Machine Break-In.....	23
Choke Lever.....	18	Machine Set-up.....	25
Fuel Shut-off Valve.....	18	Operating Hints.....	27
Ignition Switch.....	18	Pre-operation Checklist.....	23
Recoil Starter.....	19	Starting the Engine.....	26
Throttle Lever.....	19	Vertical Splitting (WX540, WX540L only).....	28
Engine Fuel.....	32	Operating Safety.....	22
Engine Oil.....	32	Operation.....	
Engine Oil Level Check.....	24	Starting the Engine.....	26
Equipment Safety Guidelines.....	10	Stopping in an Emergency.....	26
F		P	
Familiarization.....	16	Personal Protective Equipment (PPE).....	9
Job Site Familiarization.....	16	Pre-operation.....	23
Machine Components.....	17	Product Labels.....	7
To the New Operator.....	16	Product Warranty.....	6
Training.....	16	Putting Wood Splitter in Storage.....	
Fluids.....	32	Removing from Storage.....	31
Fuel Level – Checking.....	25	R	
Fuel Shut-off Valve.....	18	Refueling.....	25
G		Refueling Safety.....	10
Gas Motor Safety.....	11	Replacing Damaged Safety Signs.....	15
Grease Points.....	33	Rotate Splitter to Vertical.....	28
H		S	
Hydraulic Fitting Torque.....	40	Safe Condition.....	10
Hydraulic Oil.....	32	Safety.....	8
Hydraulic Oil – Adding.....	24	Equipment Safety Guidelines.....	10
Hydraulic Oil – Changing.....	35	Gas Motor Safety.....	11
Hydraulic Oil Level Check.....	24	Hydraulic Safety.....	10
Hydraulic Oil Type.....	24	Maintenance Safety.....	32
Hydraulic reservoir volume.....	35	Operating Safety.....	22
		Personal Protective Equipment (PPE).....	9
		Preparation.....	12

Refueling Safety	10
Safety Alert Symbol	8
Safety Do's and Don'ts	9
Safety Training.....	10
Signal Words	8
Tire Safety	10
Transport Safety	29
Safety Alert Symbol.....	8
Safety Notice Labels	7
Safety Sign Explanations	15
Safety Sign Locations	14
Safety Signs.....	14
Safety Sign Locations.....	14
Safety Training	10
Serial Number Location.....	5
Service and Maintenance.....	32
Electrical System	36
Fluids and Lubricants.....	32
Grease Points.....	33
Hydraulic Oil – Changing.....	35
Hydraulic Oil Filter – Changing.....	35
Maintenance Schedule	33
Sign-off form.....	13
Specifications	38
Common Bolt Torque Values	39
Hydraulic Fitting Torque	40
Machine Specifications.....	38
Wheel Lug Torque.....	40
WX540, WX540L	38
Splitter Operation	
Before Starting the Engine.....	22
Engine Oil Level Check	24
Fuel Level Check.....	25
Hydraulic Oil Level Check.....	24
Machine Break-In.....	23
Pre-operation Checklist	23
Splitting Wood	27
Starter	19
Stopping in an Emergency	26
Storing the Wood Splitter	31
Stroke Limiter Accessory.....	21
Stroke Limiter Adjustment	21

T

Throttle Lever	19
Transporting	29
Connecting a Tow Vehicle.....	30
Prepare for Transport.....	30
Troubleshooting Guide	37

V

Vertical Splitting.....	28
-------------------------	----

W

Wheel Lug Torque	40
------------------------	----



www.wallensteinequipment.com