

EMB Manufacturing Inc.

4144 Boomer Line · St. Clements, On · N0B 2M0 · Canada
Ph: (519) 699-9283 · Fax: (519) 699-4146
www.embmfg.com

Accessory Installation Instructions 6-WAY WEDGE

Time saving 6 Way Wedge, splits wood into smaller more manageable pieces

This Instruction applies to Way Wedge kit:

P600 (2089W571)

P601 (2089W572)



This Safety Alert symbol means

ATTENTION! BECOME ALERT! YOUR SAFETY IS INVOLVED!

The Safety Alert symbol identifies important safety messages in this instruction, as well as on the Wood Processor and in the operators manual. When you see this symbol, be alert to the possibility of personal injury or death. Follow the instructions in the safety message.



Always wear the appropriate safety gear when installing this kit or working around the machine. This includes but is not limited to:

- Hard hat for protection to the head.
- Face mask for protection to the face and eyes from flying chips.
- Heavy gloves for protection from slivers, chips and pinching.
- Safety shoes with slip resistant soles and steel toes.

6 Way Wedge Installation:

Kit P600 (2089W571): fits Wood Processor models: WP230, WP260, WP630, WP820, WP830 and WP860.

Kit P601 (2089W572): fits Wood Processor models: WP235, WP265, WP635, WP825, WP835 and WP865.



Caution: wedge is constructed of heavy gauge steel, be sure to use caution moving and installing the kit, avoid dropping or pinching body parts on corners and edges of the kit.

P600 / P601 kits comes completely assembled. Although the kits fit specific models, installation procedure is the same for both, follow the instructions to complete the installation.

Before you start, you'll need:

- Rags.

For replacement parts, go to www.embmfg.com and click on "Parts and Manuals" to download the latest parts manual for your model, then call your dealer to order.

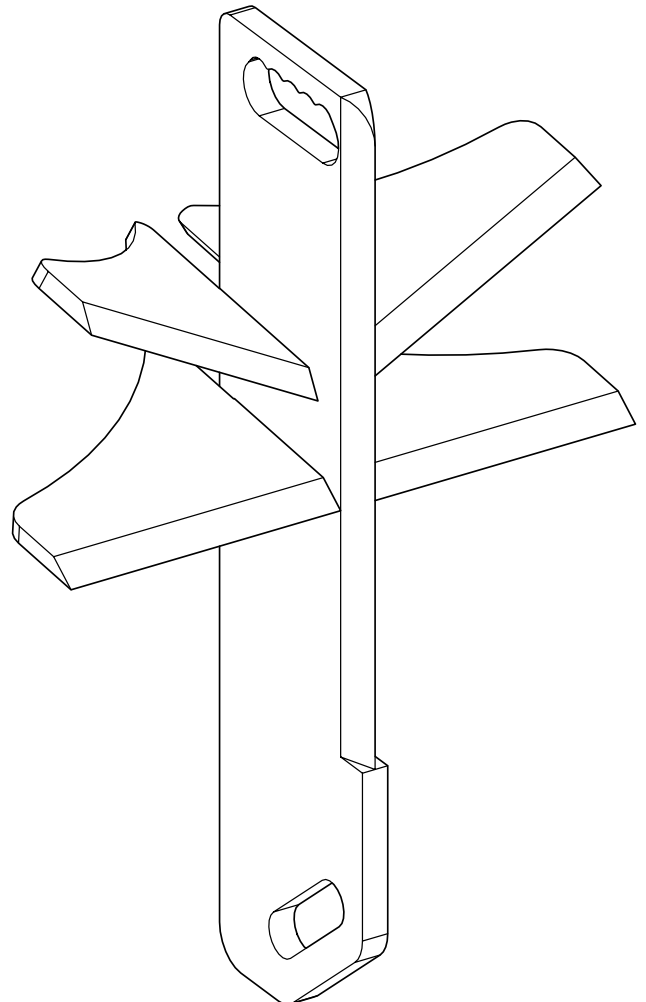

over:

Installation Instructions:

 Ensure the Wood Processor is not powered on, and the area around it is clean and free of debris and resting on dry level ground. Clean any debris on or around the 4 way wedge.

1. Facing the hydraulic controls, move the wedge height lever all the way to the right, to take the tension off of the lever and lower the wedge to a safe position for removal.
 2. Find where the wedge attaches to the height lever, and remove the latch pin.
 3. On the far side of the wedge, Carefully grasp the hitch pin and remove it and the roller sleeve from the wedge.
 4. The wedge is now free to remove.
 5. Find the splitter chute height adjuster and remove the latch pin, then carefully grasp the hitch pin and remove it from height adjuster.
 6. You will then be able to raise the splitter chute up into its folded position, to gain access to the wedge.
 7. Lift the wedge straight up till it clears the chute bottom, then lift the wedge out of the chute area.
 8. Grab the 6 way wedge by the lifting handle and lift it into position, make sure the wedge is oriented properly, line up with the wedge support and insert it where the 4 way wedge was.
 9. Set the wedge down, then align and insert the roller sleeve in the slot at the bottom of the wedge, install the hitch pin through the sleeve, and install the latch pin.
 10. Lower the splitter chute back into position, then replace the hitch pin and latch pin onto the height adjuster
 11. Ensure the height lever and wedge move freely, and everything is secure.
- Your new 6 way wedge is ready to use.

