

PARTS MANUAL

Serial Number 152R559 & up

BX52R / RI **3 PH ROLLER-FEED CHIPPER**

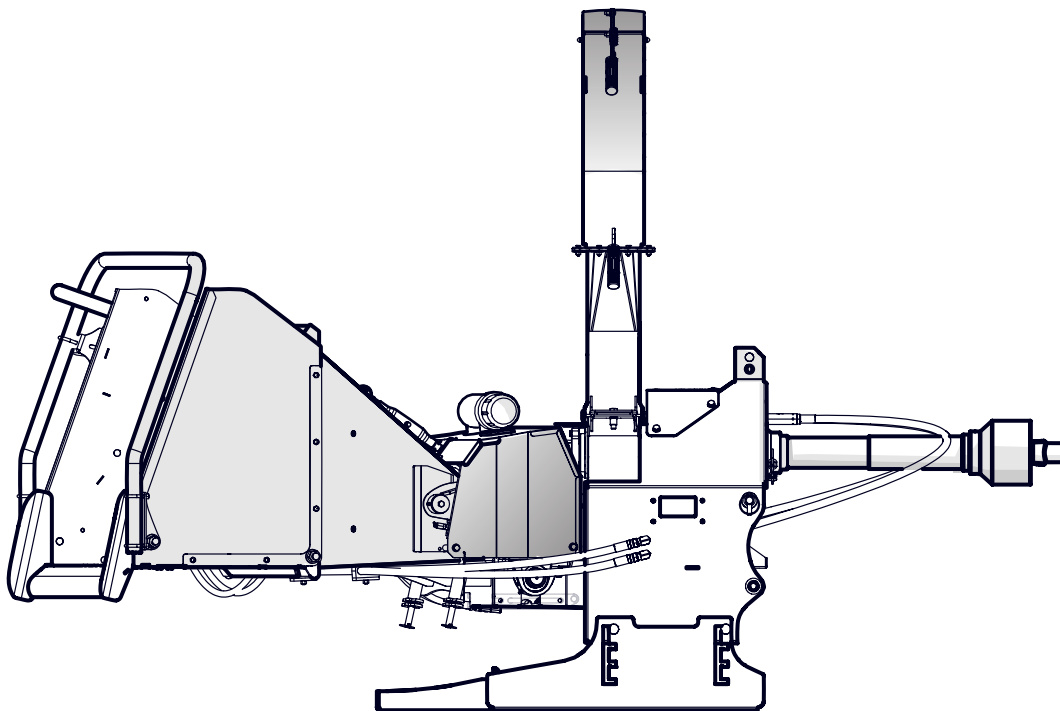

Foreword

This Wallenstein parts manual is prepared to assist customers in ordering quality OEM replacement parts.

Regular maintenance combined with replacing old, worn or broken parts with the correct OEM parts is essential in prolonging the life of your Wallenstein product. Refer to this manual to identify replacement parts.

To order parts, contact your Wallenstein dealer or distributor. Have the product model and serial number handy.

If your dealer is no longer available, please go to our website: <http://wallensteinequipment.com> and click on the [Dealer Locator](#) to find the nearest dealer.

All information contained in this parts manual is current as per the revision date at the bottom of the page. Wallenstein reserves the right to change product specifications at any time without notice.

If your product specifications differ from those contained in this manual, contact Wallenstein for current information.

Reproduction of information in this parts manual is prohibited without prior written permission from Wallenstein Equipment Inc.

Wallenstein Equipment Inc. • © 2019

WARNING!

Refer to the operators manual for safe operation and maintenance.

Maintenance should be performed by trained personnel only.

Serial Number Location

Always provide the model and serial number of your Wallenstein product when ordering parts or requesting service or other information. This information is found on the product information plate as shown below.

Record your product information here for future reference.

Model _____

Serial Number _____

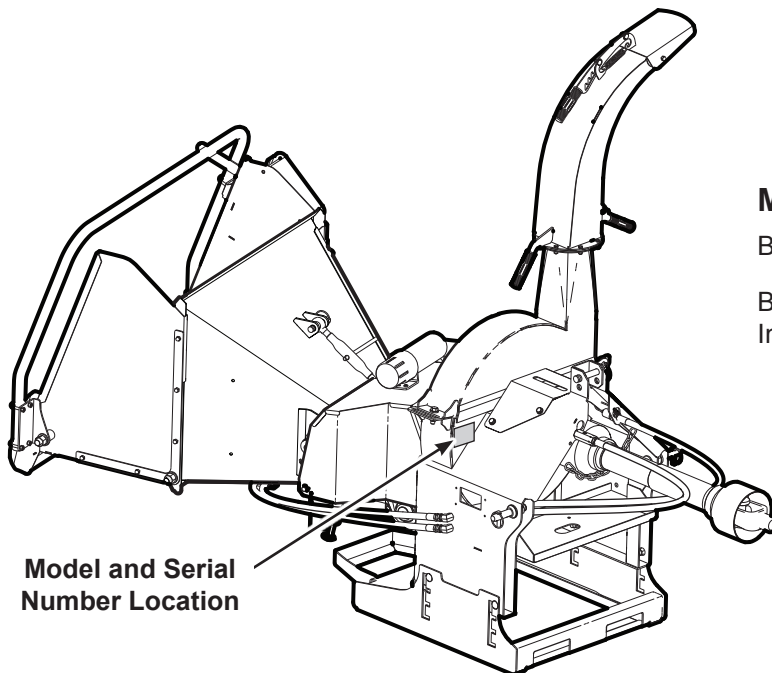

Model and Serial Number Location

Models covered in this manual:

BX52R – Roller-feed Chipper

BX52RI – Roller-feed Chipper with IntelliFEED

www.wallensteinequipment.com

Contents

Rotor Assembly.....	4
Lower Rotor Housing	5
Upper Rotor Housing.....	6
Ledger Knife Detail	7
Discharge Chute	8
Upper Roller Detail	9
Right Upper Roller Pivot Assembly	10
Left Upper Roller Pivot Assembly	11
Lower Roller Assembly	12
Main Hopper Assembly	13
Feed Table Assembly.....	14
Feed Roller Valve Detail	15
Feed Roller Control Detail.....	15
PTO Shaft #Z44504	16
Hydraulic Plumbing Diagram.....	17
Hydraulic Plumbing Diagram.....	18
Decal Layout.....	19
Accessories	21
Common Bolt Torque Values	22
Hydraulic Fitting Torque Values	23

Rotor Assembly

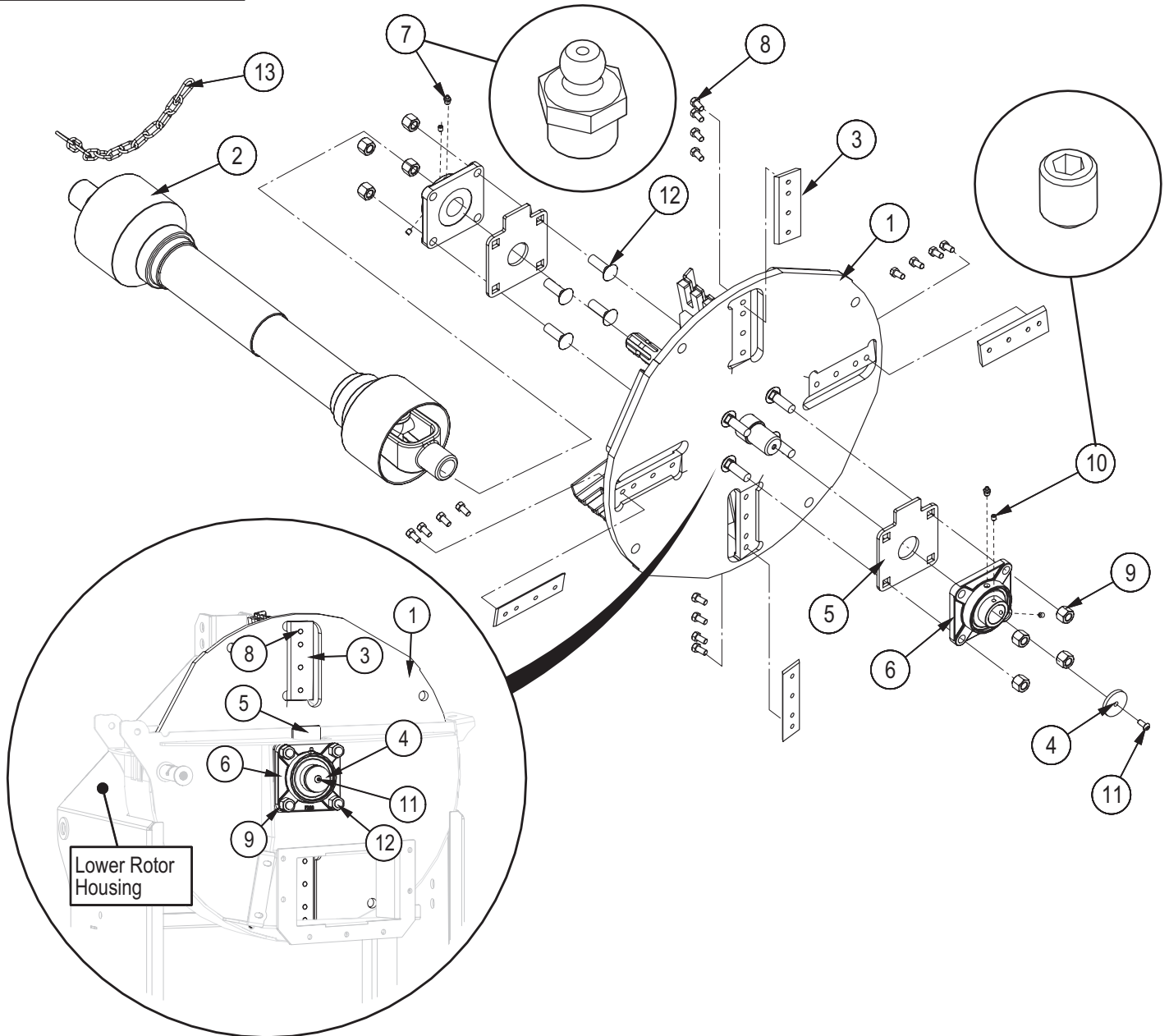

Item No.	Part No.	Description	Qty
1	1024W501	Roller Feed Rotor, 5" Capacity	1
2	Z44504	#5 Global PTO Shaft M10 Shear	1
3	1011M103	Knife, 4" Rotor	4
4	1021S102	Rotation Indicator Cover	1
5	1024L107	Bearing Plate, BX52	2
6	Z25204	4-Bolt Flange Bearing, 1-1/2" Bore	2
7	Z29201	Grease Fitting, 1/8NPT	2
8	Z71373G8	Hex Bolt, 3/8NF x 3/4 G8	16
9	Z72261G8	Hex Lock Nut, 5/8NC G8	8
10	Z74122	Set Screw, 5/16NF x 3/8"	4
11	Z75351	BHCS, 5/16NF x 3/4"	1
12	Z76261G8	Carriage Bolt, 5/8NC x 2" G8	8
13	Z92310	Chain 3/16" x 12" double hook ends	1

Lower Rotor Housing

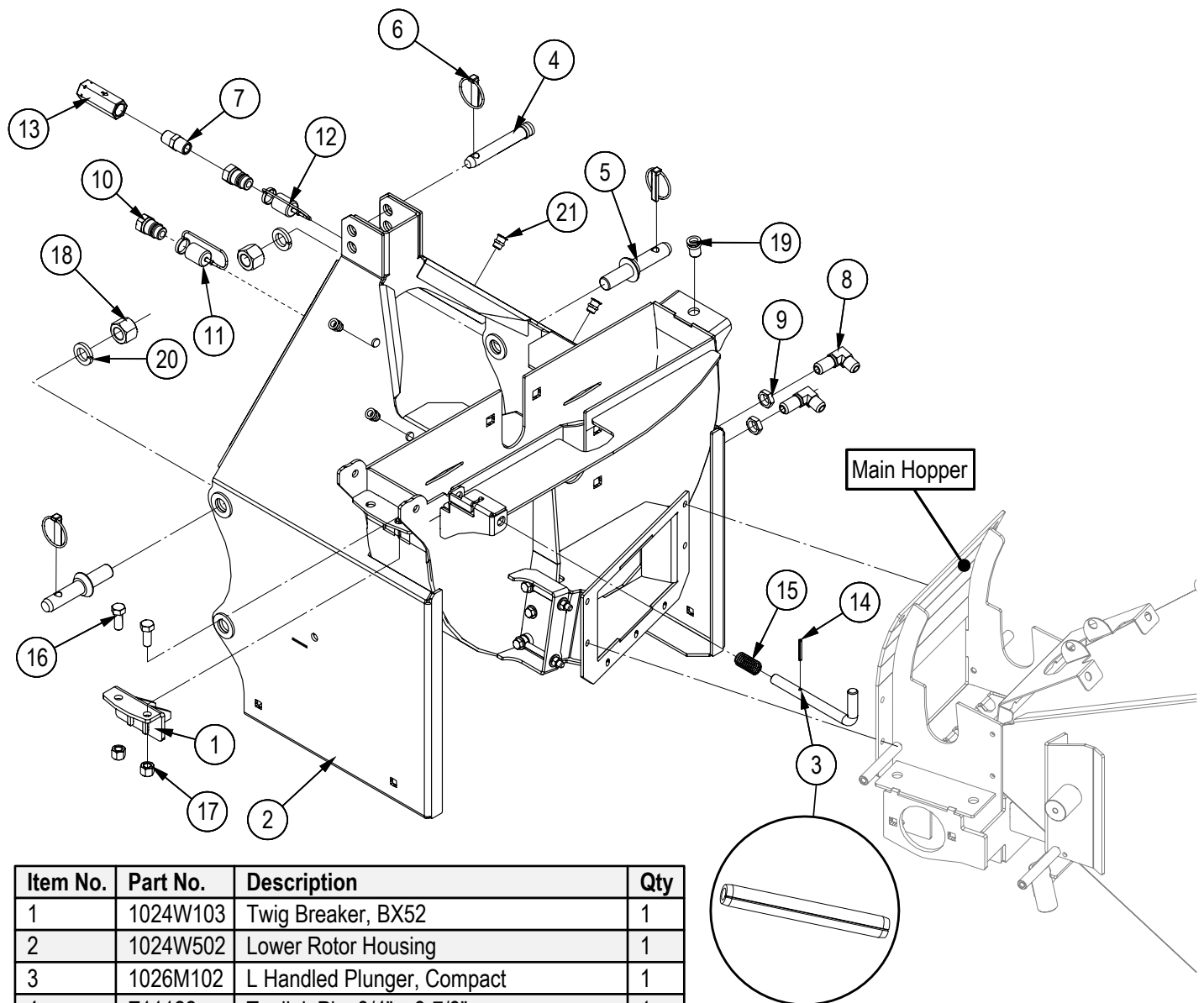

Item No.	Part No.	Description	Qty
1	1024W103	Twig Breaker, BX52	1
2	1024W502	Lower Rotor Housing	1
3	1026M102	L Handled Plunger, Compact	1
4	Z11122	Toplink Pin, 3/4" x 3-7/8"	1
5	Z11431	Implement Pin, 7/8" x 1-3/4" x 7/8NF	2
6	Z12140	Lynch Pin, 7/16"	3
7	Z51122	Straight, MP x MP 0808	1
8	Z51492	Elbow 90, MJIC x BH 0808	2
9	Z51493	BH Locknut, 08	2
10	Z51926	Quick Coupler, FP08 x M ISO 7241-1	2
11	Z52831	Nipple Cap, ISO 7241-1 x Red	1
12	Z52832	Nipple Cap, ISO 7241-1 x Black	1
13	Z56102	Check Valve, FP08 x 0PSI	1
14	Z14151	Roll Pin, 3/16" x 1-1/2"	1
15	Z32305	Comp Spring, 0.845" OD x 3-1/2" x 0.085"	1
16	Z71512	Hex Bolt, 1/2NC x 1-1/4"	2
17	Z72251	Hex Lock Nut, 1/2NC	2
18	Z72282	Hex Lock Nut, 7/8NF	2
19	Z72960	Rivet Nut, 1/2NC x 200	1
20	Z73381	Split Lock Washer, 7/8"	2
21	Z77940	Rivet Nut, M10x1.5 x 313	4

Upper Rotor Housing

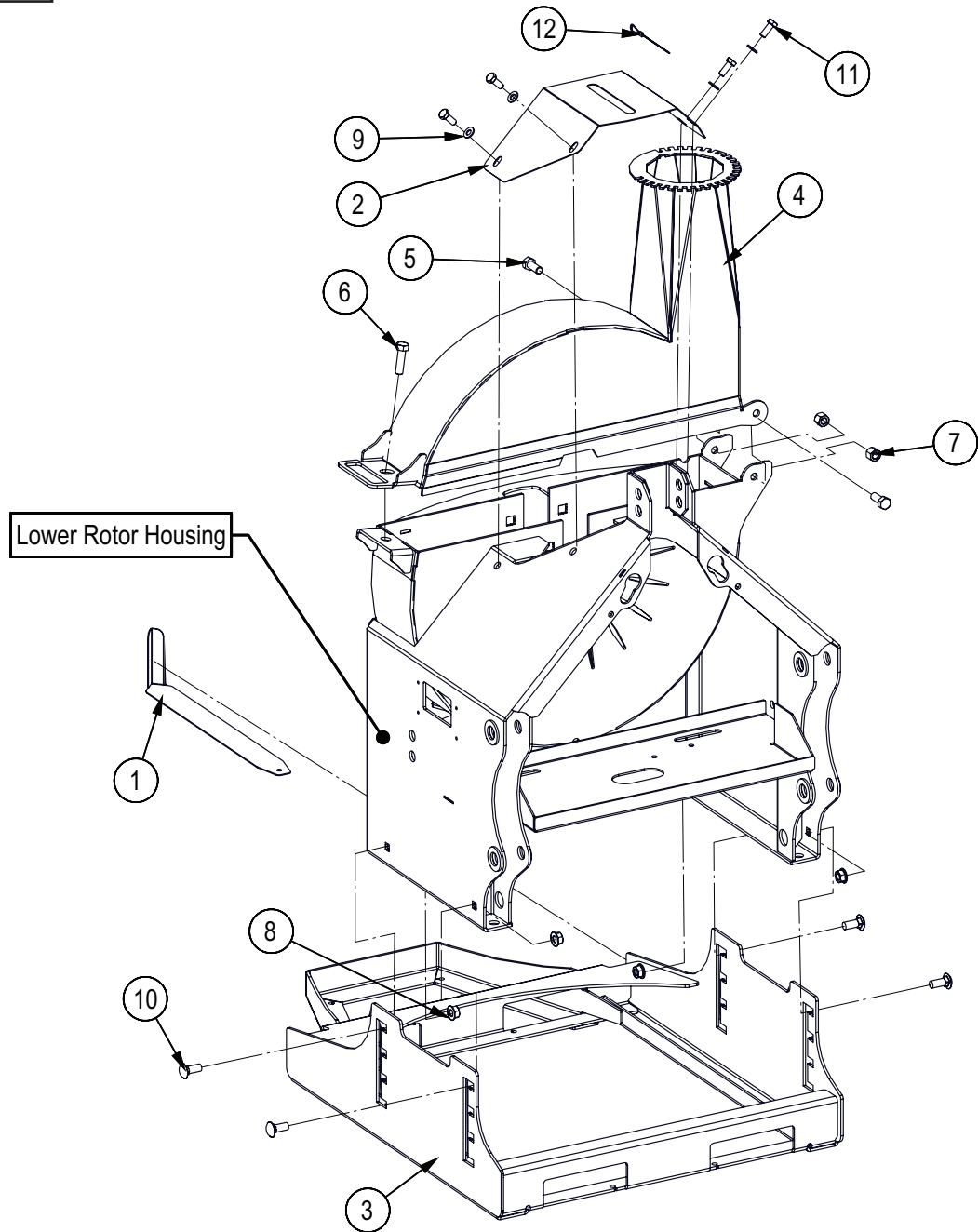

Item No.	Part No.	Description	Qty
1	1024L161	Gauge, Ledger Setting	1
2	1024L554	PTO Guard	1
3	1024W709	BX52R Extended Base	1
4	1024W104	Upper Rotor Housing	1
5	Z71512	Hex Bolt, 1/2NC x 1-1/4"	2
6	Z76155	Flange Bolt, 1/2NC x 1-3/4"	1
7	Z72251	Hex Lock Nut, 1/2NC	2
8	Z72551	Serrated Flange Locknut, 1/2NC	4
9	Z73131	SAE Washer, 3/8"	4
10	Z76259	Carriage Bolt, 1/2NC x 1-1/4"	4
11	Z77162	Hex Bolt, M10x1.5 x 25mm	4
12	Z92127	1/16 Aircraft cable x 16"	1

Ledger Knife Detail

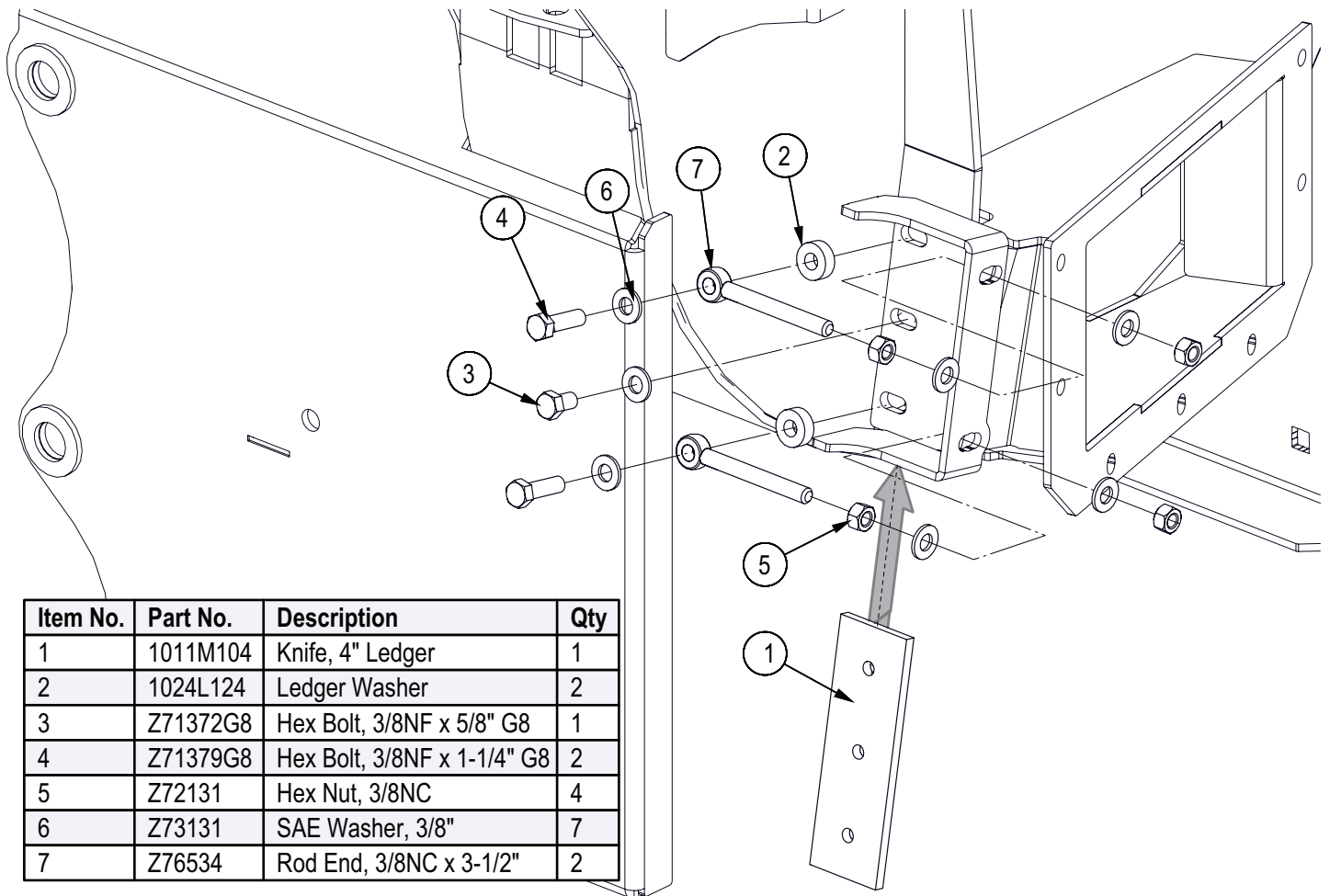

Item No.	Part No.	Description	Qty
1	1011M104	Knife, 4" Ledger	1
2	1024L124	Ledger Washer	2
3	Z71372G8	Hex Bolt, 3/8NF x 5/8" G8	1
4	Z71379G8	Hex Bolt, 3/8NF x 1-1/4" G8	2
5	Z72131	Hex Nut, 3/8NC	4
6	Z73131	SAE Washer, 3/8"	7
7	Z76534	Rod End, 3/8NC x 3-1/2"	2

Discharge Chute

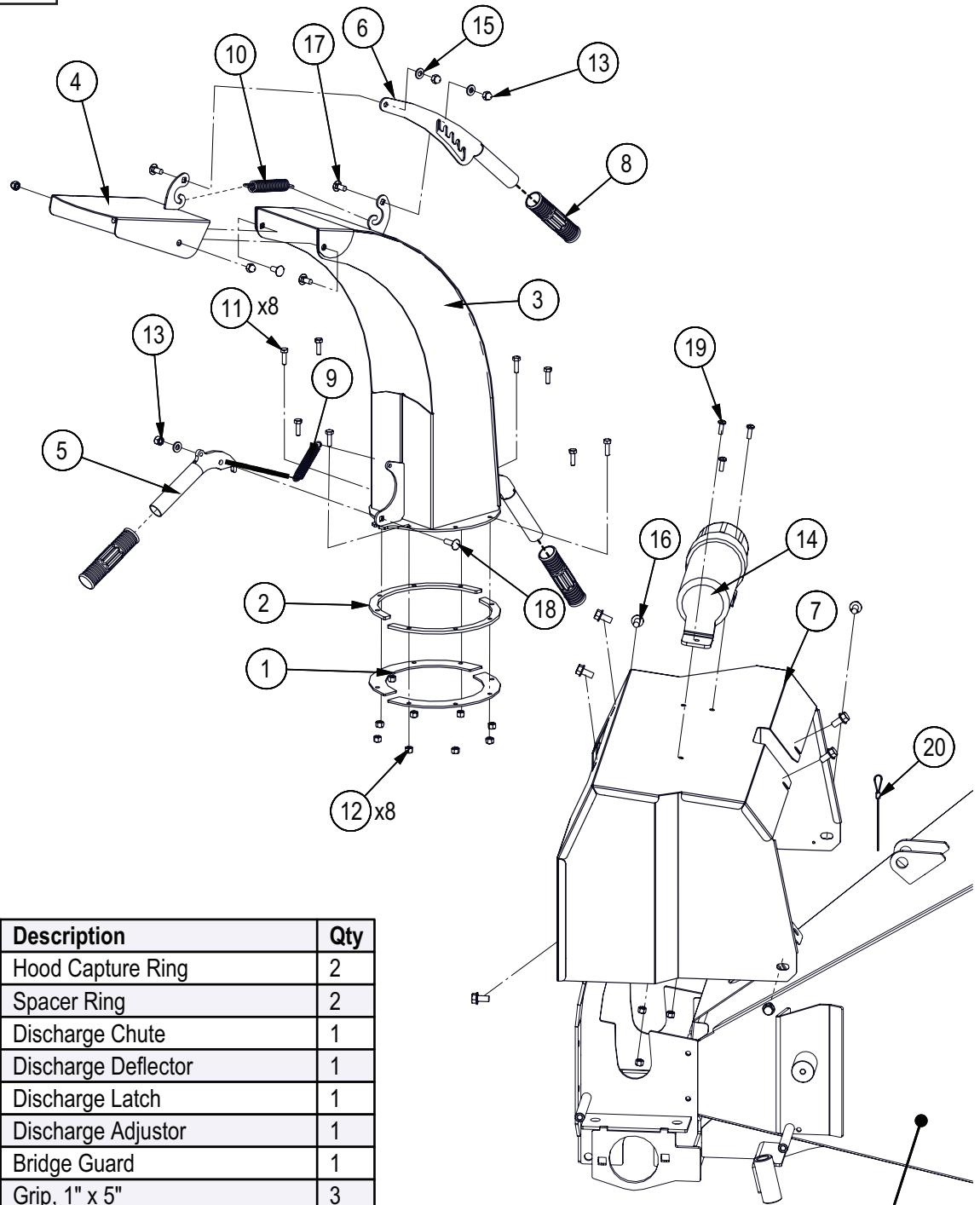

Main Hopper

Item No.	Part No.	Description	Qty
1	1024L133	Hood Capture Ring	2
2	1024L134	Spacer Ring	2
3	1024W106	Discharge Chute	1
4	1024W107	Discharge Deflector	1
5	1024W108	Discharge Latch	1
6	1024W109	Discharge Adjustor	1
7	1024W621	Bridge Guard	1
8	Z19321	Grip, 1" x 5"	3
9	Z31305	Ext Spring, 5/8" OD x 3" x 0.08"	1
10	Z31401	Ext Spring, 3/4" OD x 4" x 0.105"	1
11	Z71108	Hex Bolt, 1/4NC x 7/8"	8
12	Z72211	Hex Lock Nut, 1/4NC	11
13	Z72221	Hex Lock Nut, 5/16NC	5
14	Z96503	Manual Tube 3-1/2 Short	1
15	Z73122	SAE Washer, 5/16"	3
16	Z76133	Flange Bolt, 3/8NC x 3/4"	8
17	Z76221	Carriage Bolt, 5/16NC x 3/4"	4
18	Z76225	Carriage Bolt, 5/16NC x 1"	1
19	Z78301	Machine Screw, 1/4NC x 3/4"	3
20	Z92110	1/16 Aircraft cable x 2'	1

Upper Roller Detail

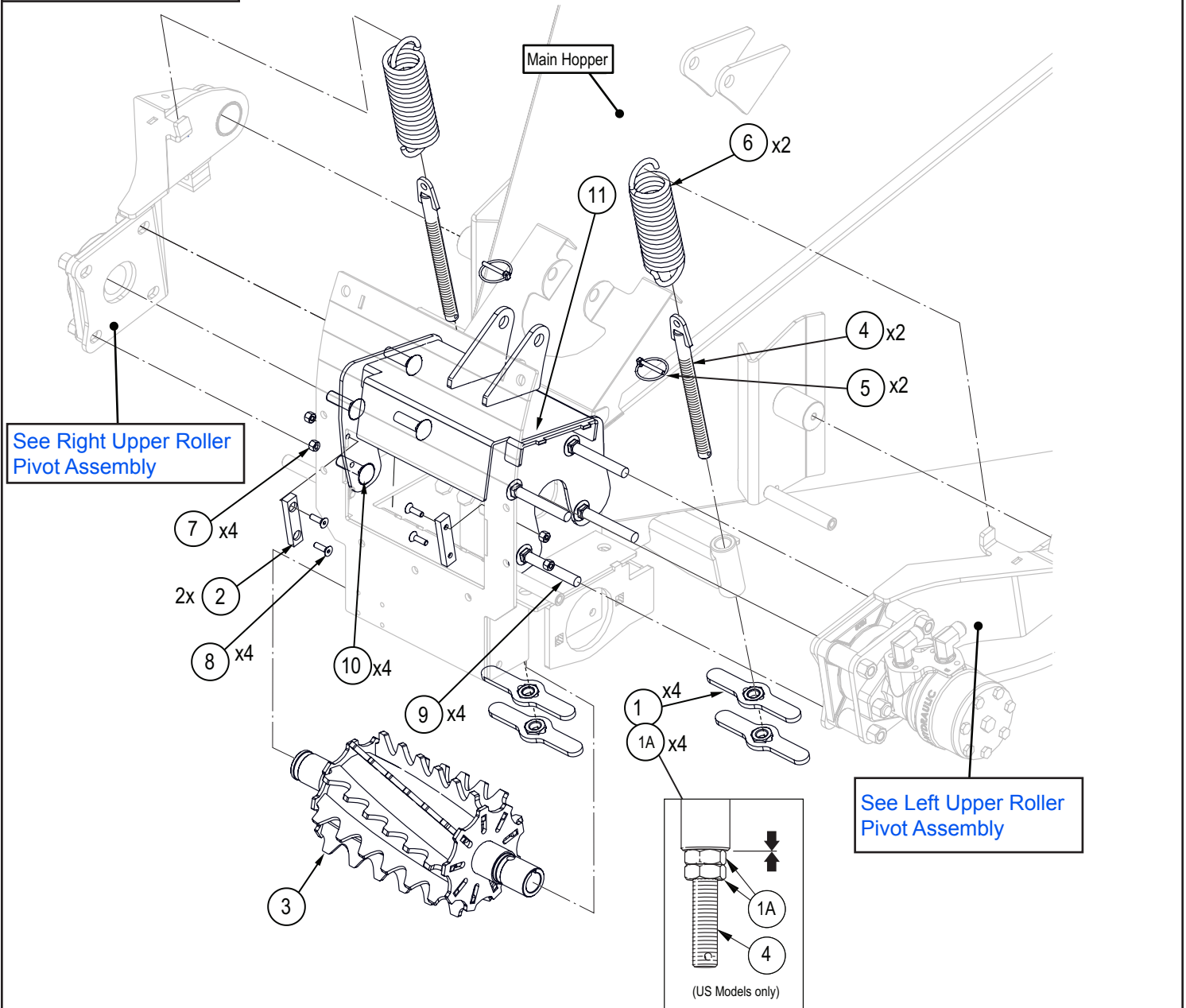

Item No.	Part No.	Description	Qty
1	1022W220	Nut Handle	4
1A	Z72361	Jam Nut, 5/8NC (US Models only)	4
2	1024S707	Rotor Hood Slide	2
3	1024W710	Upper Feed Roller, Spiral Overlap	1
4	1024W708	Spring Yoke	2
5	Z12110	Lynch Pin, 3/16"	2
6	Z31501	Ext Spring, 2" OD x 7" x 0.250"	2
7	Z72211	Hex Lock Nut, 1/4NC	4
8	Z75211	FHCS, 1/4NC x 7/8"	4
9	Z762510	Carriage Bolt, 1/2NC x 3-1/2"	4
10	Z76258	Carriage Bolt, 1/2NC x 1-3/4"	4
11	1024W618	Bridge	1

Right Upper Roller Pivot Assembly

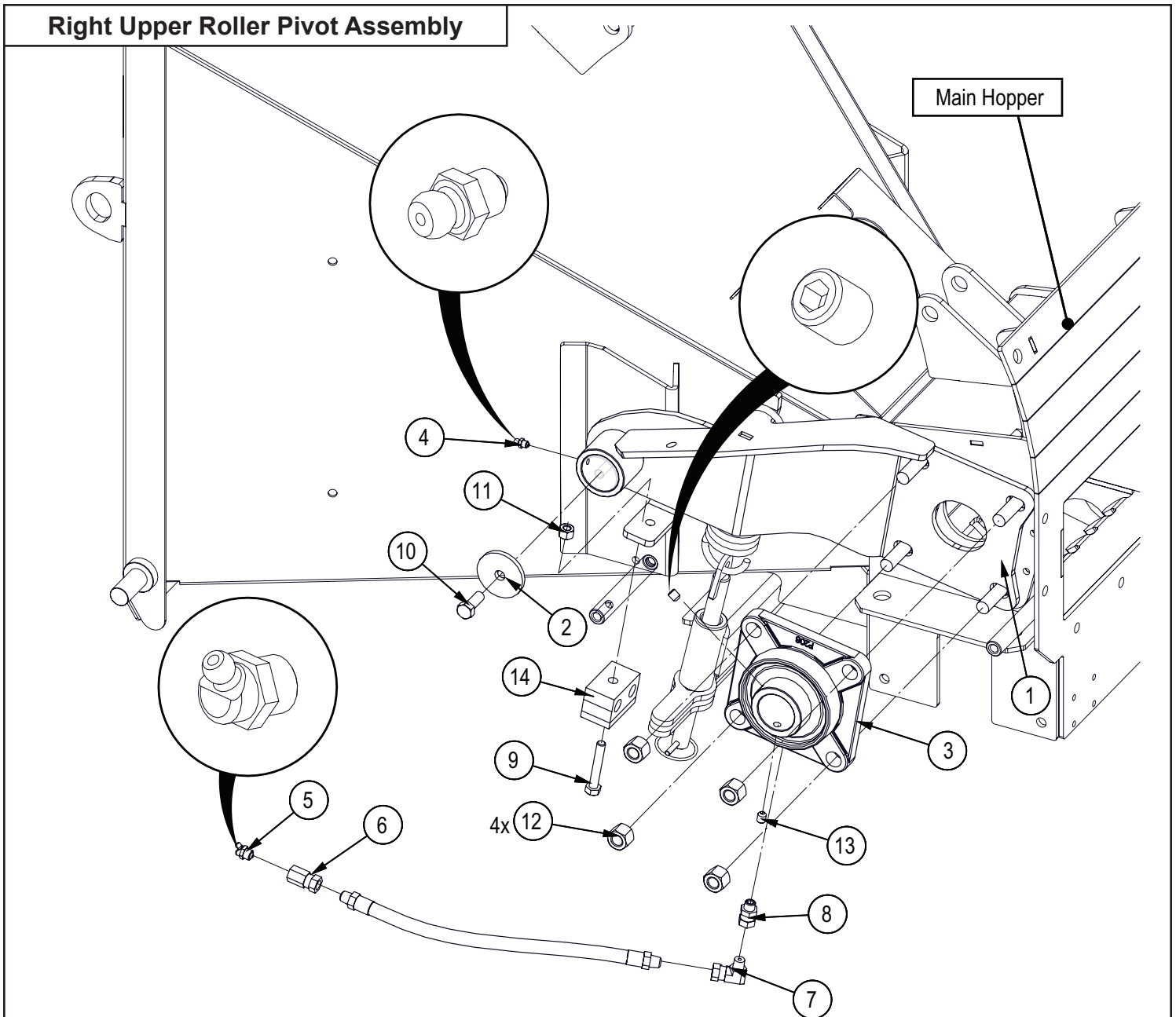

Item No.	Part No.	Description	Qty
1	1024W602H	Roller Pivot Arm RH	1
2	1024L618	Capture Washer	1
3	Z25204	4-Bolt Flange Bearing, UCF208-24	1
4	Z29202	Grease Fitting, 1/4NF	1
5	Z29204	Elbow 45 Grease Fitting, MP02	1
6	Z29302	Grease Fitting, FP x FPX 0202	1
7	Z29307	Elbow 90 Grease Fitting, MP x FPX 0202	1
8	Z29311	Grease Fitting, MP x FPX 0202	1
9	Z71220	Hex Bolt, 5/16NC x 2"	1
10	Z71310	Hex Bolt, 3/8NC x 1"	1
11	Z72221	Hex Lock Nut, 5/16NC	1
12	Z72251	Hex Lock Nut, 1/2NC	4
13	Z74122	Set Screw, 5/16NF x 3/8"	2
14	Z79462	Double Hose Clamp, 1/2" OD	1

Left Upper Roller Pivot Assembly

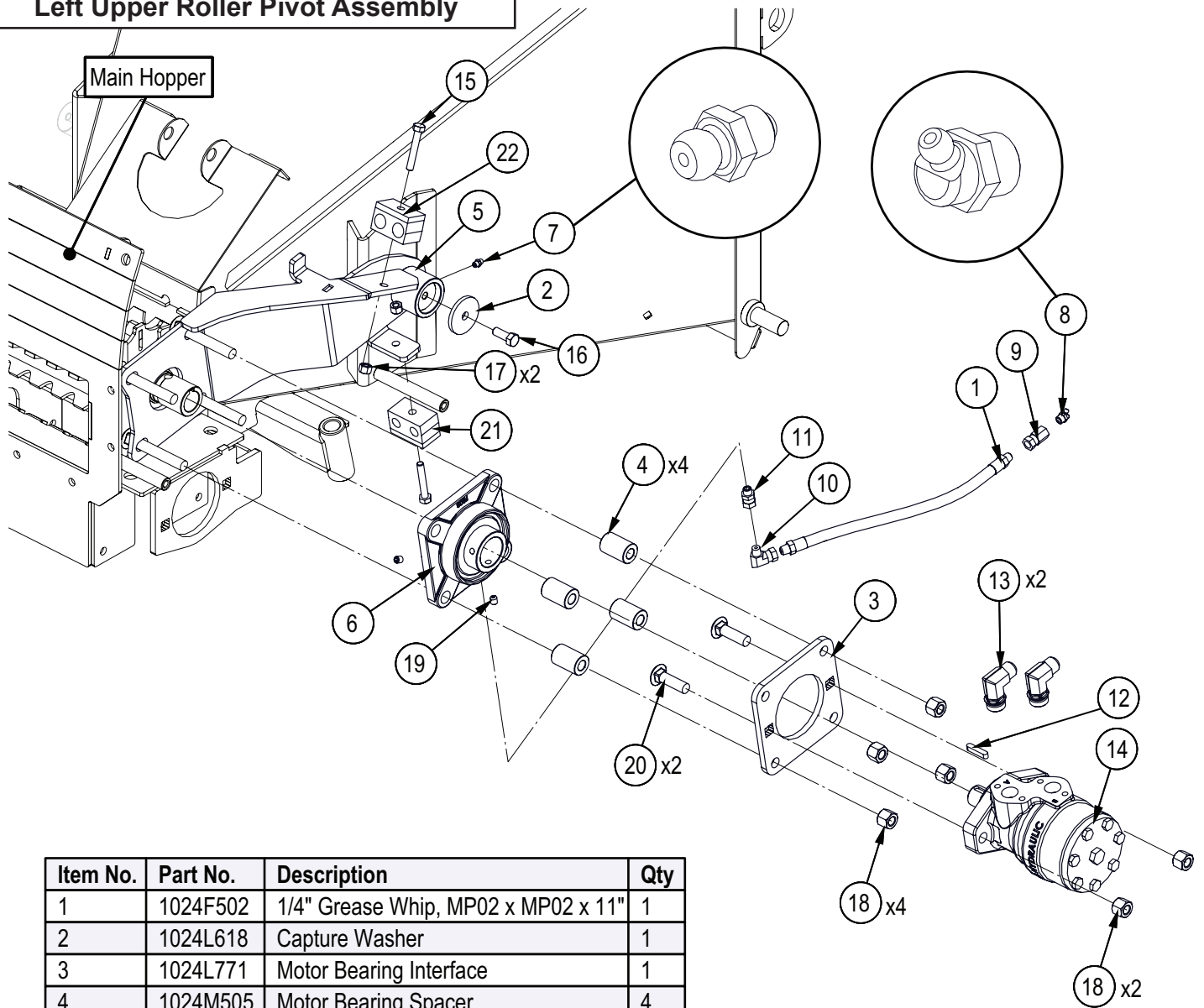

Item No.	Part No.	Description	Qty
1	1024F502	1/4" Grease Whip, MP02 x MP02 x 11"	1
2	1024L618	Capture Washer	1
3	1024L771	Motor Bearing Interface	1
4	1024M505	Motor Bearing Spacer	4
5	1024W602	Roller Pivot Arm LH	1
6	Z25204	4-Bolt Flange Bearing, 1-1/2" Bore	1
7	Z29202	Grease Zerk 1/4NF	1
8	Z29204	Grease Fitting, 1/8NPT x 45	1
9	Z29302	Straight, FP x FPX 0202	1
10	Z29307	Elbow 90 MP x FPX 0202	1
11	Z29311	Straight, MP x FPX 0202	1
12	Z46594	Blind Chipper Key 1/4 x 1-1/4	1
13	Z51658	Elbow 90, MJIC x MORB 0810	2
14	Z54102	Hydraulic Motor, 200CCR	1
15	Z71220	Hex Bolt, 5/16NC x 2"	2
16	Z71310	Hex Bolt, 3/8NC x 1"	1
17	Z72221	Hex Lock Nut, 5/16NC	2
18	Z72251	Hex Lock Nut, 1/2NC	6
19	Z74122	Set Screw, 5/16NF x 3/8"	2
20	Z76258	Carriage Bolt, 1/2NC x 1-3/4"	2
21	Z79462	Double Hose Clamp, 1/2" OD	1
22	Z79463	Double Hose Clamp, 11/16" OD	1

Lower Roller Assembly

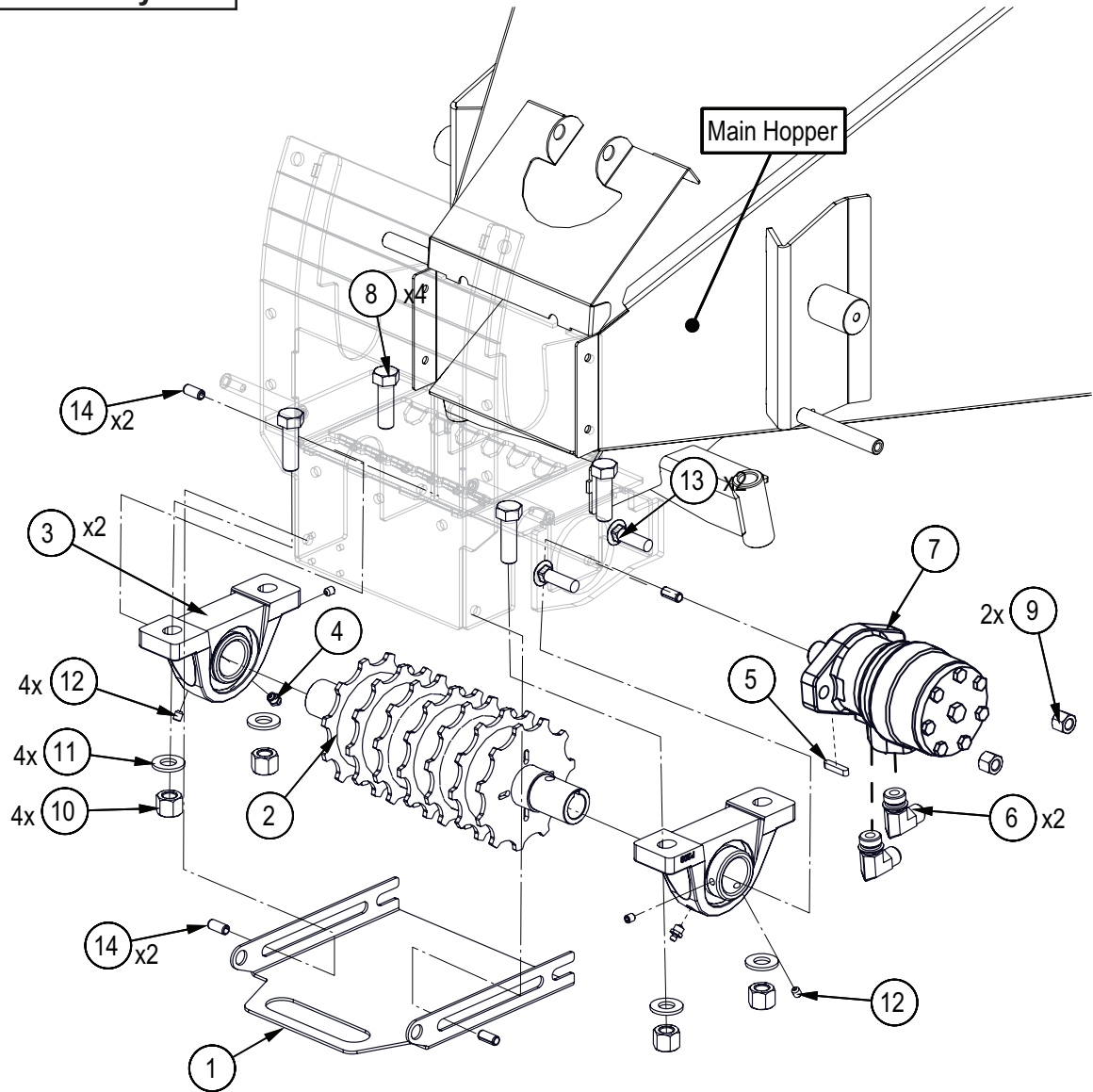

Item No.	Part No.	Description	Qty
1	1024L774	Lower Roller Guard	1
2	1024W605	Lower Feed Roll	1
3	Z24101	P208 Pillow Block 1-1/2	2
4	Z29201	Grease Fitting, 1/8NPT	2
5	Z46594	Blind Chipper Key 1/4 x 1-1/4	1
6	Z51658	Elbow 90, MJIC x MORB 0810	2
7	Z54102	Hydraulic Motor, 200CCR	1
8	Z71620	Hex Bolt, 5/8NC x 2"	4
9	Z72251	Hex Lock Nut, 1/2NC	2
10	Z72261	Hex Lock Nut, 5/8NC	4
11	Z73161	SAE Washer, 5/8"	4
12	Z74122	Set Screw, 5/16NF x 3/8"	4
13	Z76258	Carriage Bolt, 1/2NC x 1-3/4"	2
14	Z14301	Roll Pin, 10mm x 22mm	4

* Seal Kit SKMLHP-U/DE

Main Hopper Assembly

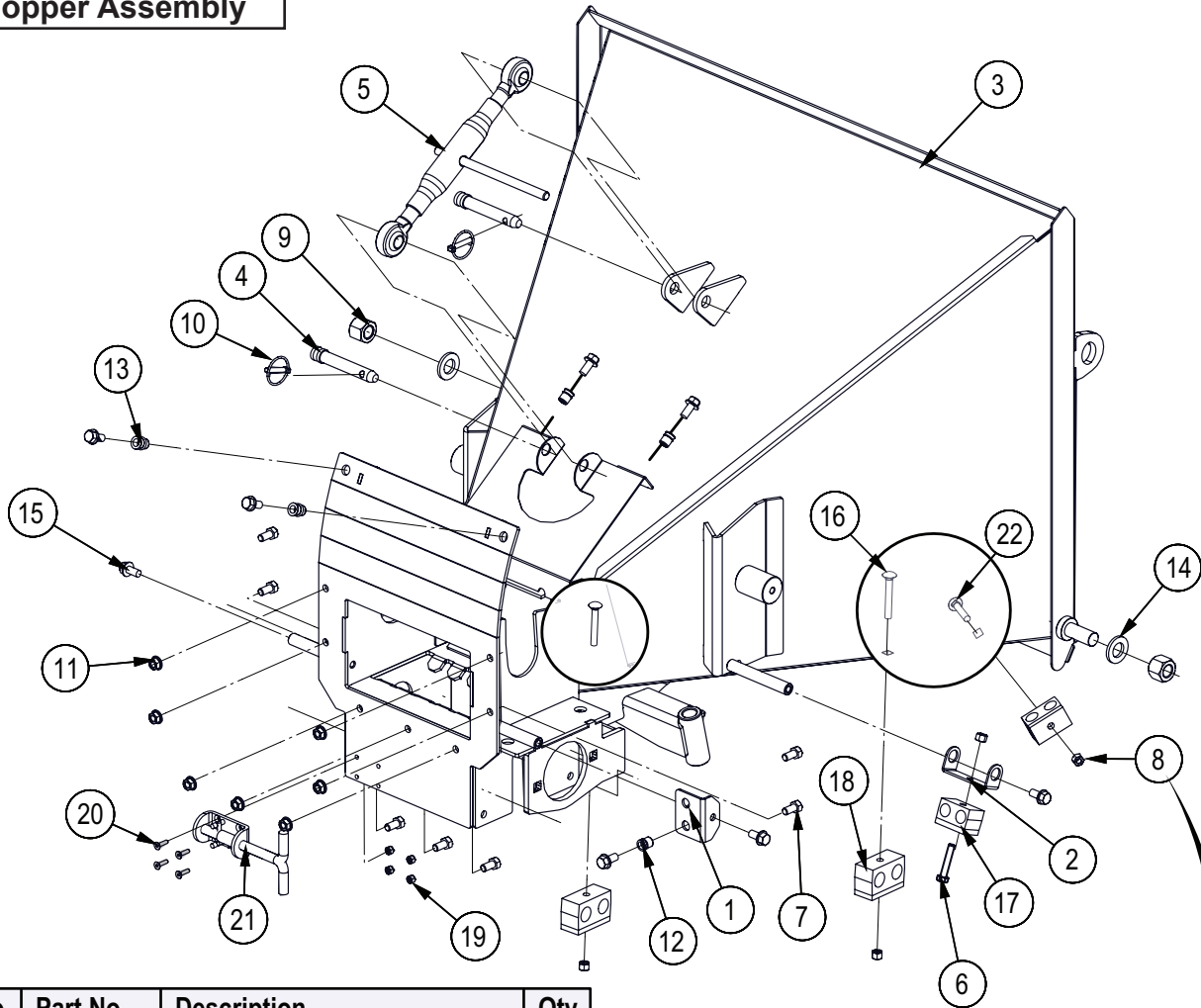

Item No.	Part No.	Description	Qty
1	1023L300	Bridge Guard Mount	1
2	1024L775	Clamp Mount	1
3	1024W601	Main Hopper	1
4	Z11111	Toplink Pin, 5/8" x 2-3/4"	2
5	Z11501	Toplink, Cat 0 x 10-1/2" x 16"	1
6	Z71217	Hex Bolt, 5/16NC x 1-3/4"	1
7	Z71307	Hex Bolt, 3/8NC x 3/4"	7
8	Z72221	Hex Lock Nut, 5/16NC	4
9	Z72271	Hex Lock Nut, 3/4NC	2
10	Z12120	Lynch Pin, 1/4"	2
11	Z72531	Serrated Flange Locknut, 3/8NC	7
12	Z72958	Rivet Nut, 3/8NC x 150	3
13	Z72959	Rivet Nut, 3/8NC x 312	2
14	Z73171	SAE Washer, 3/4"	2
15	Z76133	Flange Bolt, 3/8NC x 3/4"	9
16	Z76228	Carriage Bolt, 5/16NC x 2-1/4"	2
17	Z79463	Double Hose Clamp, 11/16" OD	2
18	Z79464	Double Hose Clamp, 13/16" OD	2
19	Z72204	Hex Lock Nut, #10NF	4
20	Z75203	FHCS, #10NF x 3/4"	4
21	Z18207	Spring Latch Pin 1/2 x 1" Stroke	1
22	Z76227	Carriage Bolt, 5/16NC x 1-3/4"	1

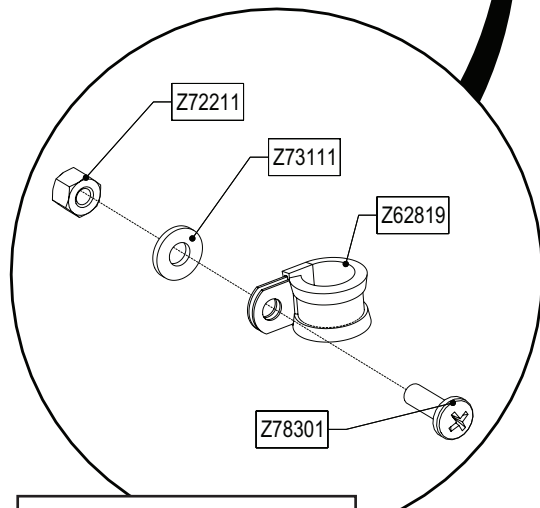

Used on BX52RI instead of # 8, 17 & 22.

Part No.	Description	Qty
Z62819	Rubberized Wire Clamp, 1/2"	1
Z72211	Hex Lock Nut, 1/4NC	1
Z73111	SAE Washer, 1/4"	1
Z78301	Machine Screw, 1/4NC x 3/4"	1

Feed Table Assembly

See Feed Roller Control Detail

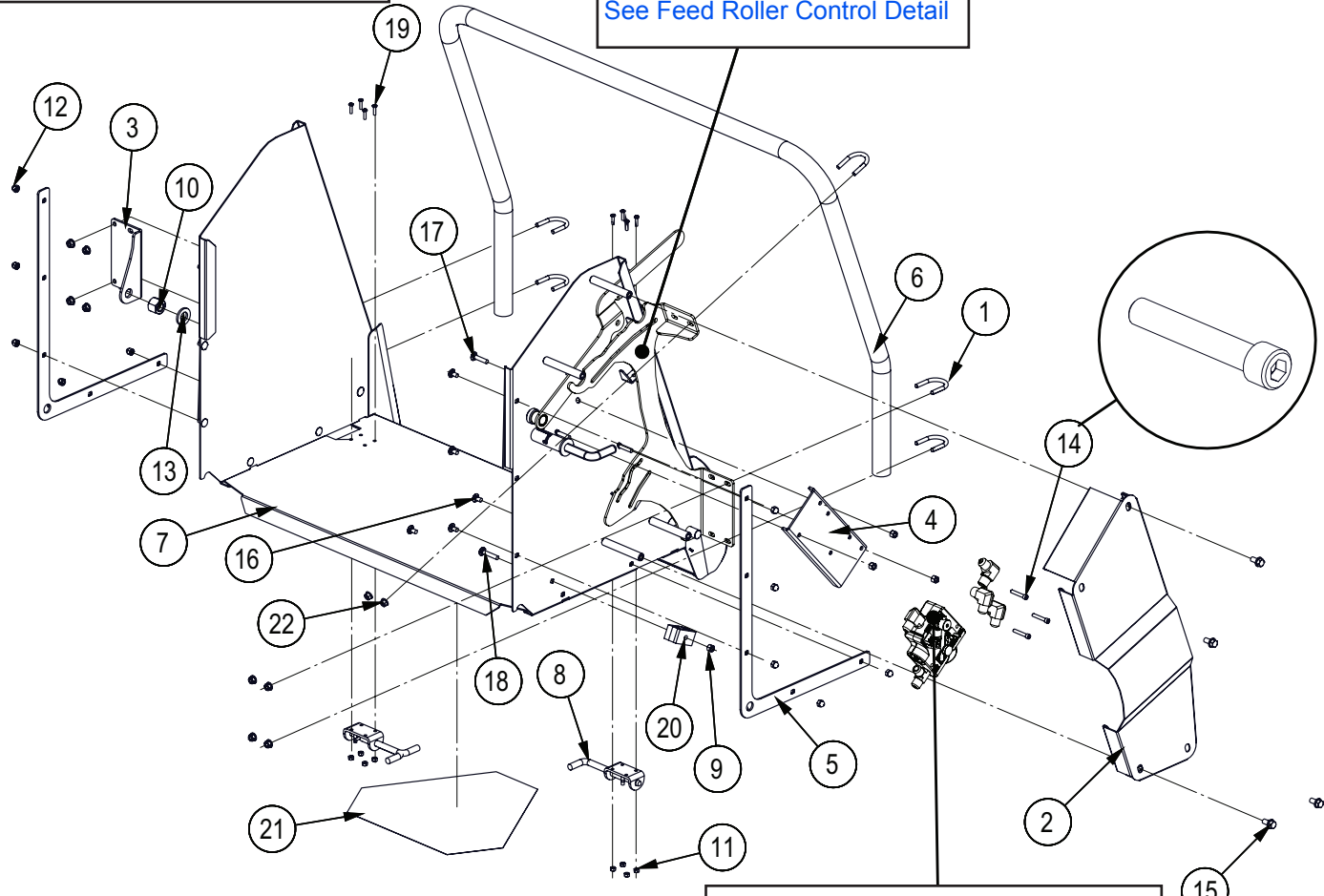

See Feed Roller Valve Detail: BX52R

Item No.	Part No.	Description	Qty
1	1015S538	U-bolt, Bearing Adapter	5
2	1022L256	Valve Guard	1
3	1022L271	Feed Control Pivot	1
4	1022W217	Valve Mount Weldment	1
5	1024L724	Fold Table Trap Plate	2
6	1024S703	Feed Control Handle	1
7	1024W704	Feed Table Weldment	1
8	Z18207	Spring Latch Pin, 1/2" x 1" Stroke	2
9	Z72221	Hex Lock Nut, 5/16NC	4
10	Z72271	Hex Lock Nut, 3/4NC	1
11	Z72204	Hex Lock Nut, #10NF	8
12	Z72914	Acorn Nut, 5/16NC	10
13	Z73171	SAE Washer, 3/4"	1
14	Z75116	SHCS, 1/4NC x 1-1/2"	3
15	Z76133	Flange Bolt, 3/8NC x 3/4"	4
16	Z76222	Carriage Bolt, 5/16NC x 5/8"	10
17	Z76224	Carriage Bolt, 5/16NC x 1-1/2"	3
18	Z76227	Carriage Bolt, 5/16NC x 1-3/4"	1
19	Z78316	Machine Screw, #10NF x 3/4"	8
20	Z79463	Double Hose Clamp, 11/16" OD	1
21	Z94601	Decal, SMV	1
22	Z72521	Serrated Flange Locknut, 5/16NC	10

Used on BX52RI instead of # 9, 18 & 20.

Part No.	Description	Qty
Z62819	Rubberized Wire Clamp, 1/2"	1
Z72211	Hex Lock Nut, 1/4NC	1
Z73111	SAE Washer, 1/4"	1
Z78301	Machine Screw, 1/4NC x 3/4"	1

Feed Roller Valve Detail

MODELS BX52R, BX52RI

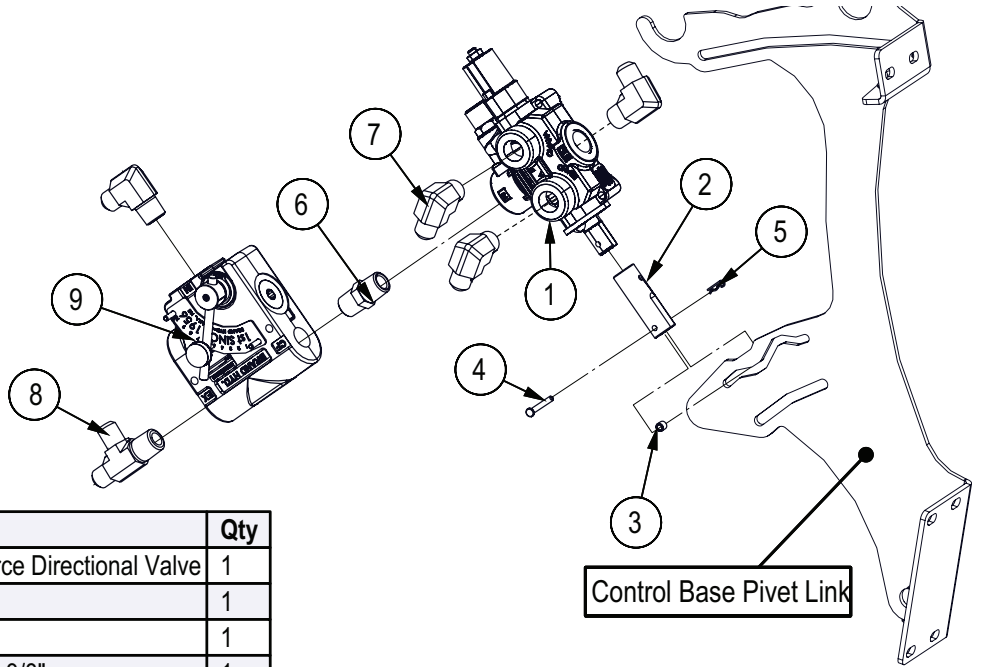

Item No.	Description	Description	Qty
1	Z56215	Spring Ctr Low Force Directional Valve	1
2	1022M213	Bearing Yoke	1
3	1022M217	Solid Bearing	1
4	Z11301	Clevis Pin 3/16 x 1-3/8"	1
5	Z12210	Hitch Pin Clip, 1/16	1
6	Z51122	Nipple, MP x MP 0808	1
7	Z51451	#8JIC x 1/2NPT 90 Elbow	4
8	Z51487	Tee MJIC x MP x MJIC 080808	1
9	Z56305	Brand PFC 0-8 GPM	1

Feed Roller Control Detail

MODELS BX52R, BX52RI

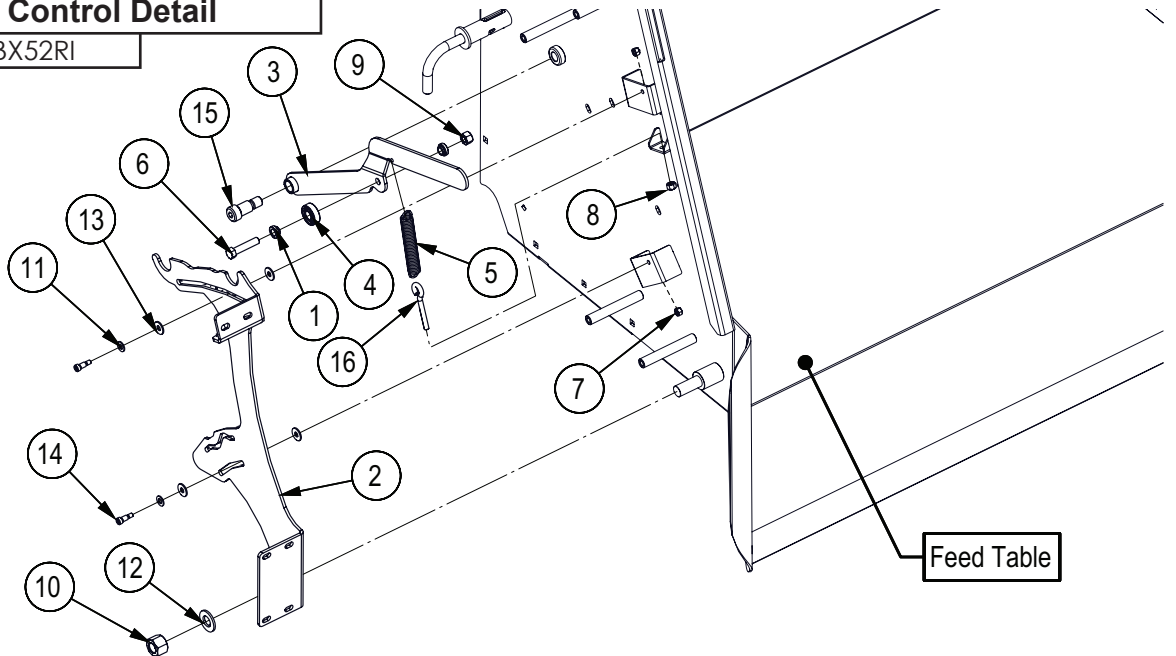

Item No.	Description	Description	Qty
1	1015M537	Bushing, Bearing	2
2	1022L239	Control Base Pivot Link	1
3	1022W224	Detent Reset	1
4	Z21203	Ball Bearing 6202 RS	1
5	Z31401	Spring 3/4 x 4" Heavy	1
6	Z71420	Hex Bolt, 7/16NC x 2	1
7	Z72211	Hex Lock Nut, 1/4NC	2
8	Z72221	Hex Lock Nut, 5/16NC	1
9	Z72241	Hex Lock Nut, 7/16NC	1

Item No.	Description	Description	Qty
10	Z72271	Hex Lock Nut, 3/4NC	1
11	Z73122	Flat Washer, 5/16	2
12	Z73171	Flat Washer, 3/4"	1
13	Z73222	PTFE Flat Washer, 5/16 x 0.080"	4
14	Z75522	Shoulder Bolt, 5/16 x 1/2"	2
15	Z75574	Shoulder Bolt, 3/4 x 1	1
16	Z76522	Eye Bolt 5/16NC x 2	1

PTO Shaft

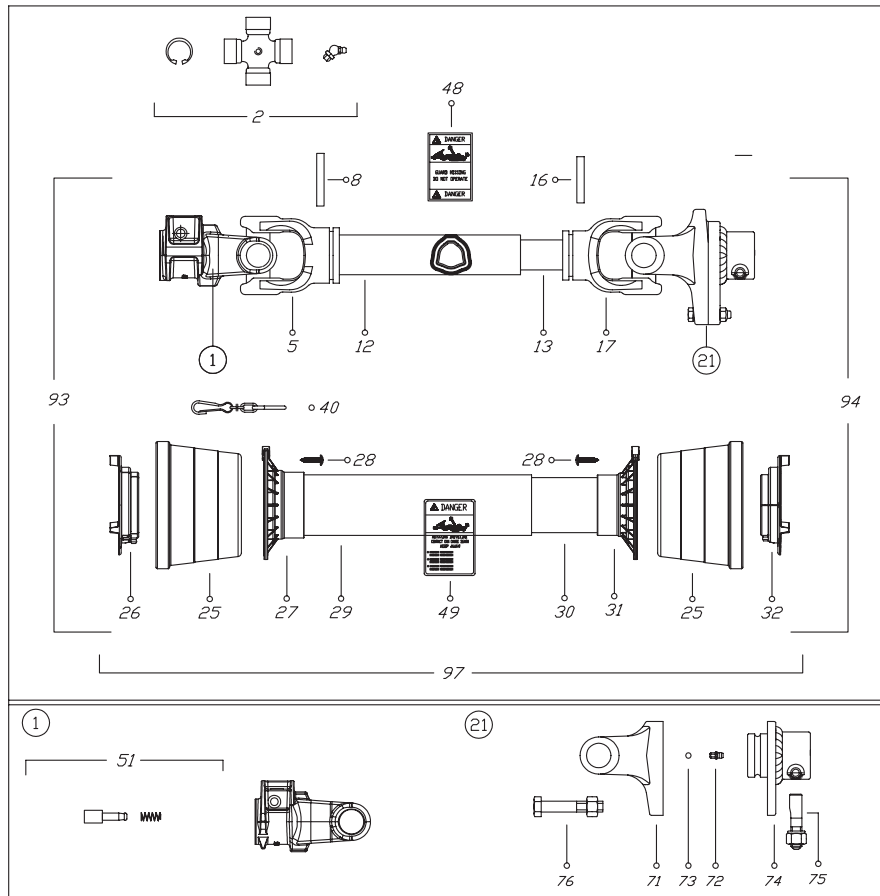

VIETATE LE RIPRODUZIONI NON AUTORIZZATE
NOT PERMITTED AL RIGHTS RESERVED

TOUTE REPRODUCTION NON AUTORISEE EST INTERDITE
NICHT GENEHMIGTE VERVIELFÄLTUNGEN SIND UNZULÄSSIG

CODICE C.E.D.
B8D061US098001

DATA
29/01/10

PTO Shaft Z44504

POS.	DESCRIPTION	Q.	Part #
01	YOKE	1	0800503
02	CROSS JOURNAL ASS.	2	08205
05	OUTER TUBE YOKE	1	08005021
08	FLEXIBLE PIN	1	098701075
12	CM. 100 CARDAN TUBE(*)	1	09881523100
13	CM. 100 CARDAN TUBE(*)	1	09881454100
16	FLEXIBLE PIN	1	0987001065
17	INNER TUBE YOKE	1	08005011
21	SHEAR BOLT M10X1.5X55	1	Z19407 (5 Pack)
25	CONE SHIELD BELL 05-06	2	021906C001
26	OUTER BEARING 05	1	025505C001
27	OUTER BASE CONE 05-06	1	025406C001
28	SCREW	6	0998052242
29	OUTER SAFETY TUBE	1	0988981NB5056
30	INNER SAFETY TUBE	1	0988975NB5056
31	INNER BASE CONE 05-06	1	025406C002
32	INNER BEARING 05	1	025505C002
40	CHAIN	1	0252000001
48	LABEL DANGER OUTER DRIVE TUBE	1	09872006
49	EXTERNAL SHIELD LABEL	1	09872003
51	COMPLETE PUSH BUTTTON	1	0986014047
71	YOKE FOR LB5	1	08896905
72	GREASE NIPPLE	1	0984010150
73	STEEL BALL	23	098680104
74	HUB	1	088965A60
75	PUSH PIN SET	1	0986014075
76	NUT AND BOLT M10 x 1.5 x 55 10.9	1	Z19407 (5 Pack)
93	OUTER HALF SHAFT	1	B5056US2
94	INNER HALF SHAFT	1	B5056US1098001
97	SAFETY GUARD	1	083US05056

Hydraulic Plumbing Diagram

MODEL BX52R

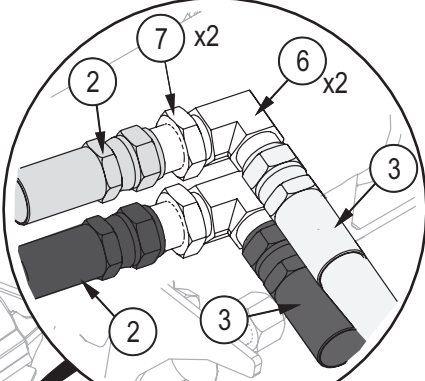
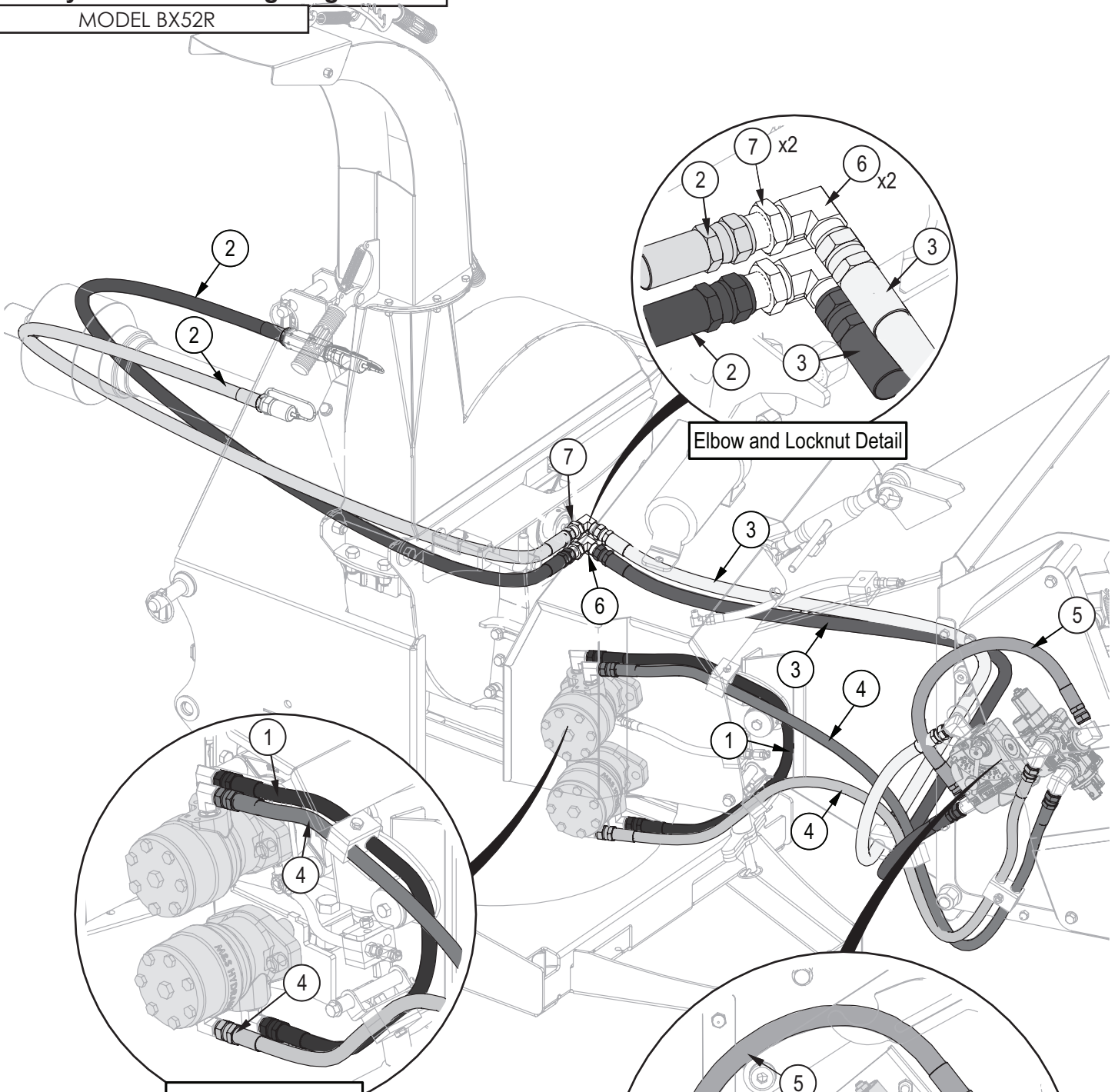

Elbow and Locknut Detail

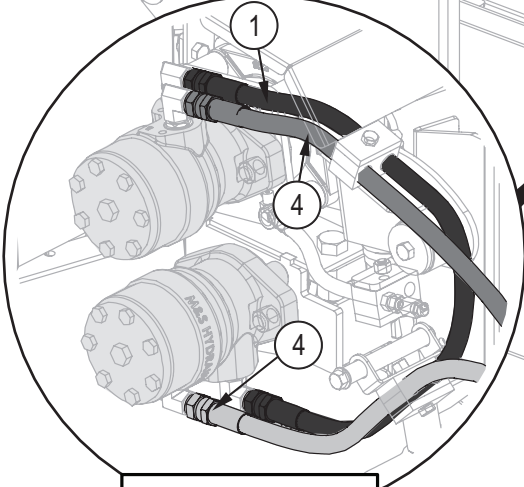

Motor Assembly Detail

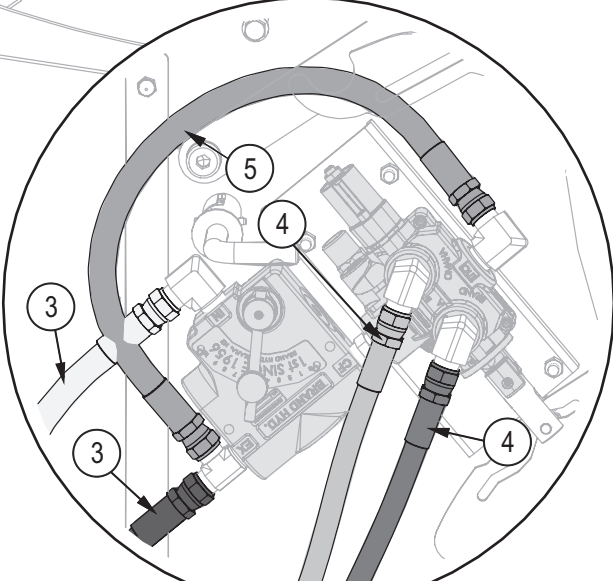

Valve Assembly Detail

Item No.	Part No.	Description	Qty
1	1024F501	3/8" Hose, FJIC08 x FJIC08 x 31"	1
2	1024F503	1/2" Hose, FJIC08 x MP08 x 54"	2
3	1024F504	1/2" Hose, FJIC08 x FJIC08 x 70"	2
4	1024F505	3/8" Hose, FJIC08 x FJIC08 x 52"	2
5	1024F701	1/2" Hose, FJIC08 x FJIC08 x 22"	1
6	Z51492	Elbow 90, MJIC x BH 0808	2
7	Z51493	BH Locknut, 08	2

Hydraulic Plumbing Diagram

MODEL BX52RI

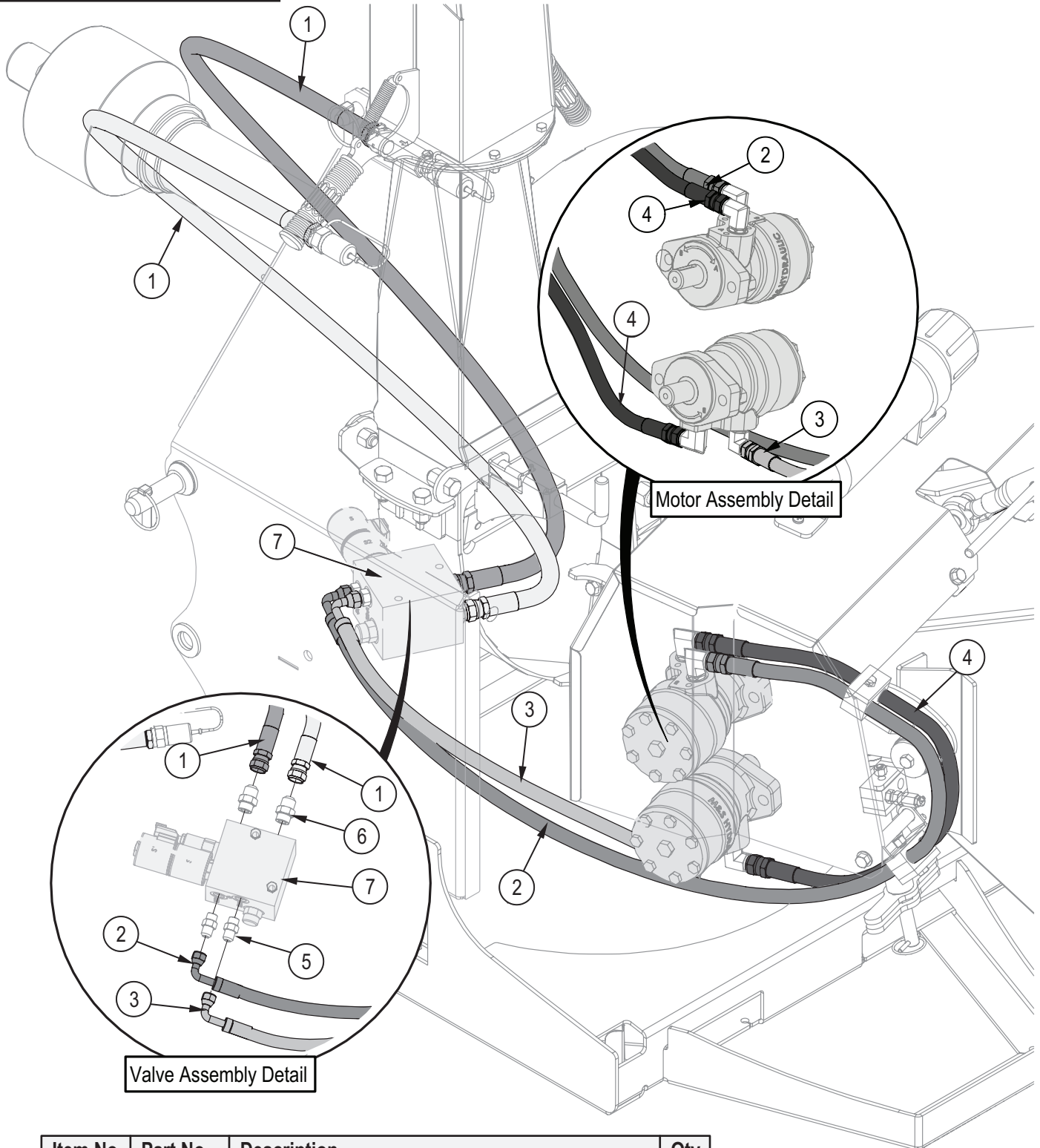

Item No.	Part No.	Description	Qty
1	1024F503	1/2" Hose, FJIC08 x MP08 x 54"	2
2	1024F702	3/8" Hose, FJIC08 x 90FJIC06 x 56"	1
3	1024F703	3/8" Hose, FJIC08 x 90FJIC06 x 21"	1
4	1024F501	3/8" Hose, FJIC08 x FJIC08 x 31"	1
5	Z51641	Straight, MJIC x MORB 0606	2
6	Z51643	Straight, MJIC x MORB 0808	2
7	Z56508	Single Spool Valve, OC Tandem PROPSOL x 6GPM	1

Decal Layout

IMPORTANT! If parts are replaced that have safety signs on them, new signs must be applied. Safety signs must always be replaced if they become damaged, are removed, or become illegible.

Safety signs are included in the product decal kit available from your authorized dealer. Decals are not available separately.

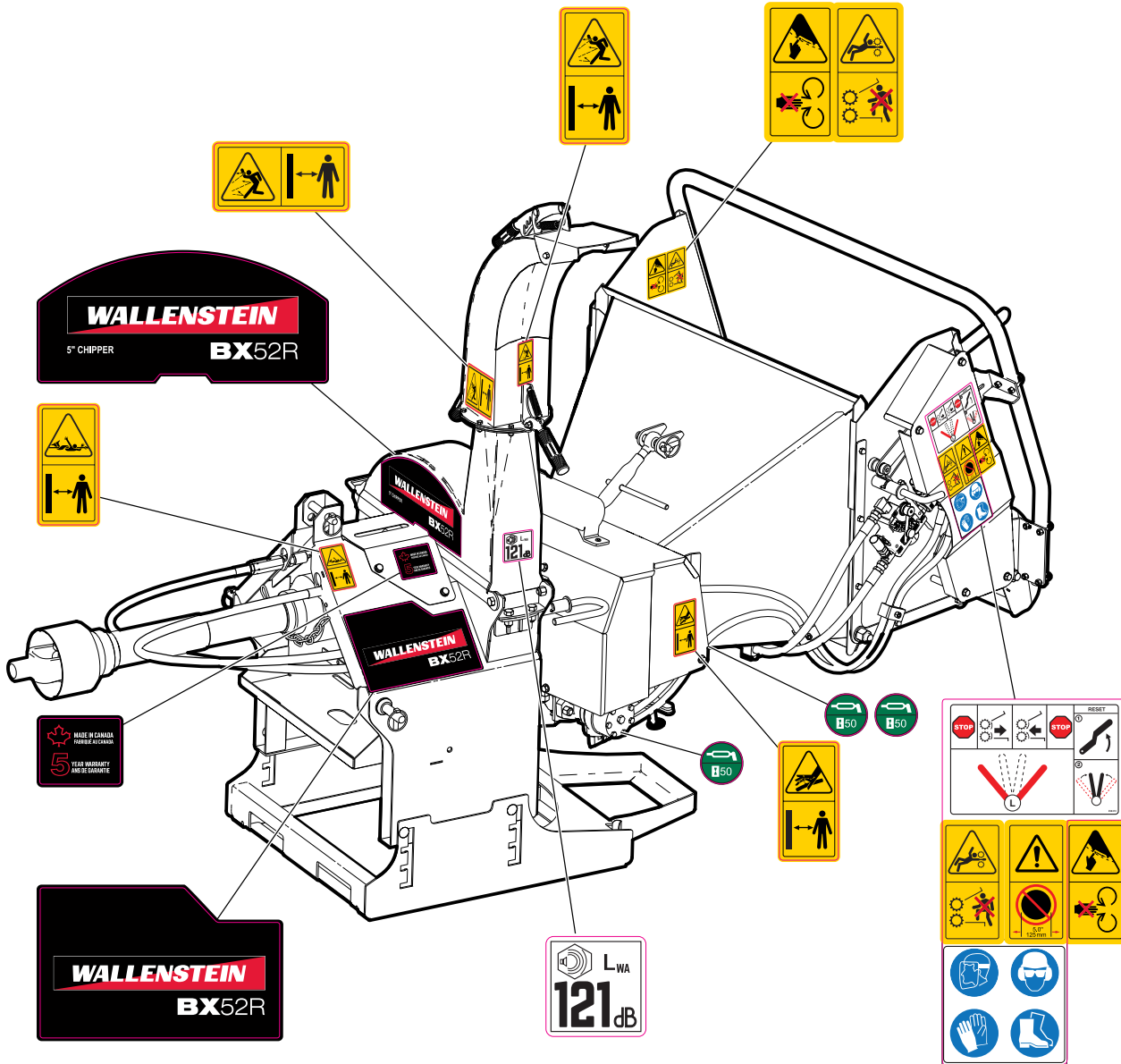

Decal Layout

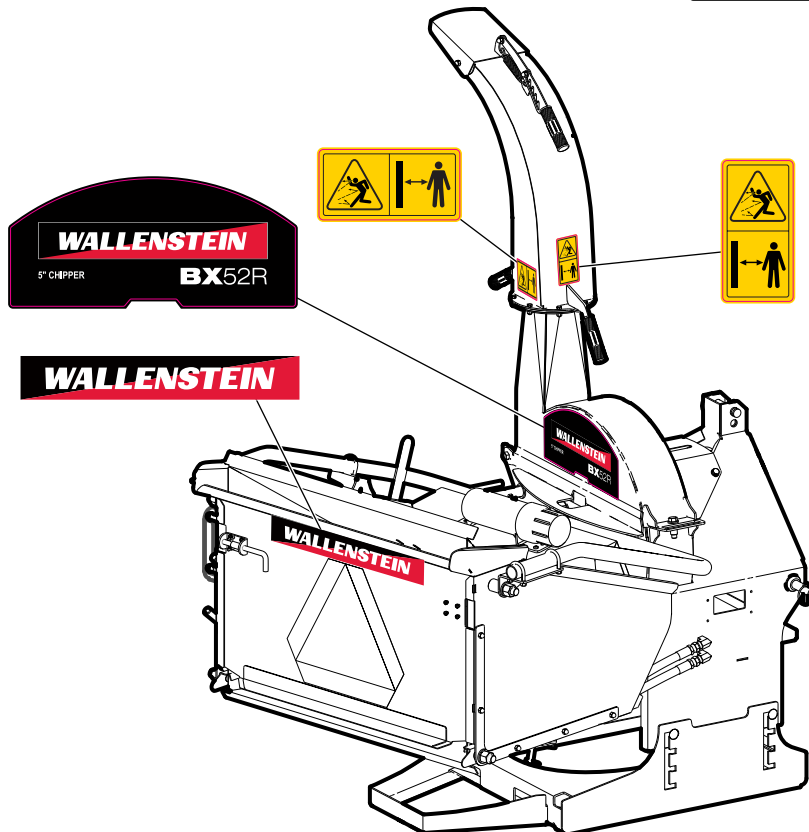
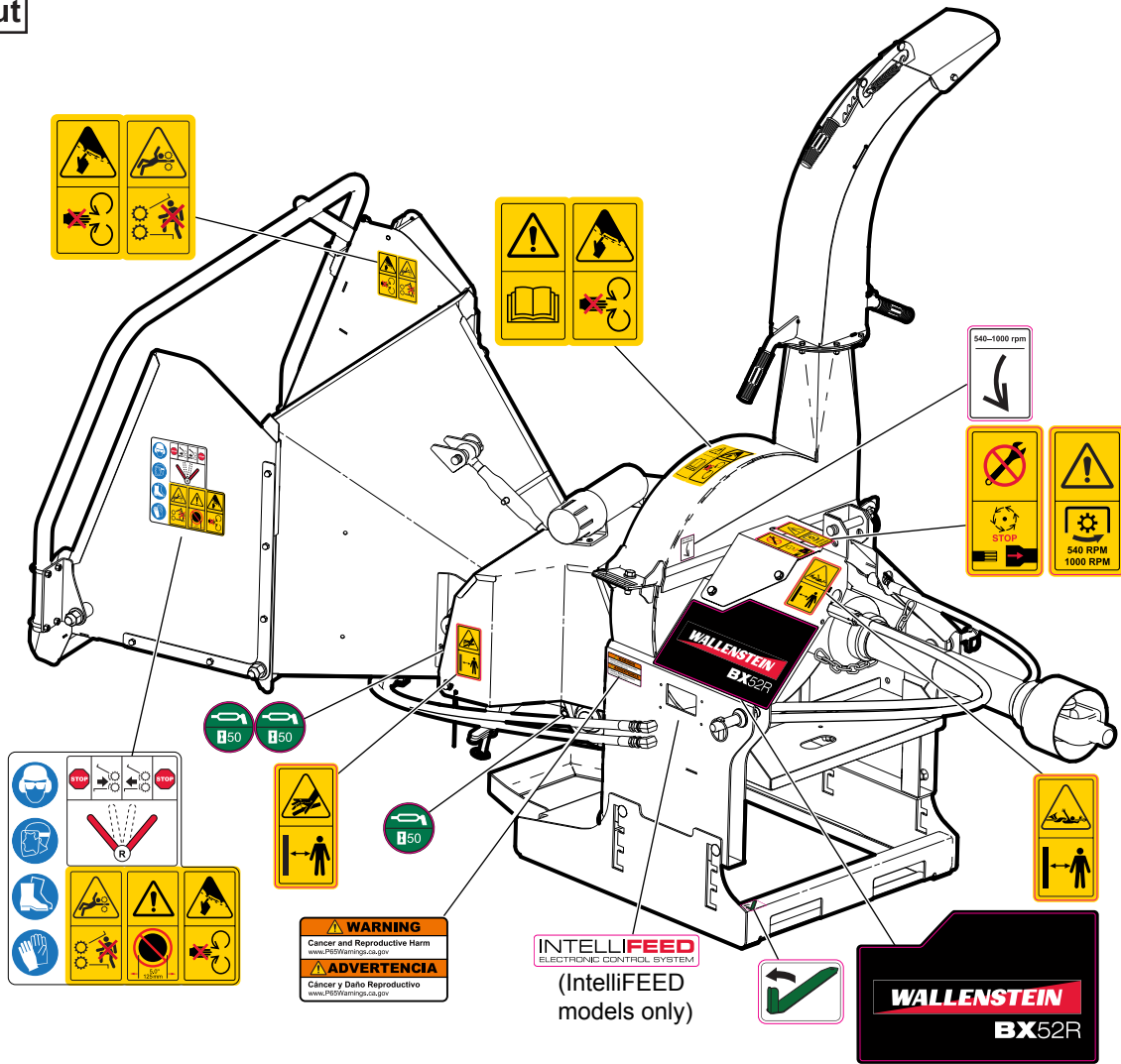

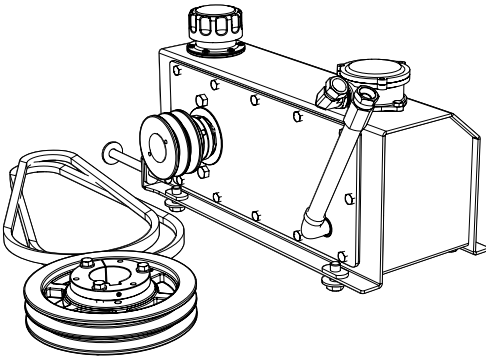
Accessories**Self-contained PTO Power Pack
P/N – C3540**

For tractors without available remote hydraulics to power the chipper self-feed control.

The power pack mounts under the PTO shaft on the chipper frame.

Common Bolt Torque Values

Checking Bolt Torque

The tables shown give correct torque values for various bolts and capscrews. Tighten all bolts to the torque values specified in the table, unless indicated otherwise. Check tightness of bolts periodically.

IMPORTANT! If replacing hardware, use fasteners of the same grade.

IMPORTANT! Torque figures indicated in the table are for non-greased or non-oiled threads. Do not grease or oil threads unless indicated otherwise. When using a thread locker, increase torque values by 5%.

 **NOTE:** Bolt grades are identified by their head markings.

Imperial Bolt Torque Specifications

Bolt Diameter	Torque Value					
	SAE Gr. 2		SAE Gr. 5		SAE Gr. 8	
	lbf•ft	N•m	lbf•ft	N•m	lbf•ft	N•m
1/4"	6	8	9	12	12	17
5/16"	10	13	19	25	27	36
3/8"	20	27	33	45	45	63
7/16"	30	41	53	72	75	100
1/2"	45	61	80	110	115	155
9/16"	60	95	115	155	165	220
5/8"	95	128	160	215	220	305
3/4"	165	225	290	390	400	540
7/8"	170	230	420	570	650	880
1"	225	345	630	850	970	1320



SAE Gr. 2



SAE Gr. 5



SAE Gr. 8

Metric Bolt Torque Specifications

Bolt Diameter	Torque Value			
	Gr. 8.8		Gr. 10.9	
	lbf•ft	N•m	lbf•ft	N•m
M3	0.4	0.5	1.3	1.8
M4	2.2	3	3.3	4.5
M6	7	10	11	15
M8	18	25	26	35
M10	37	50	52	70
M12	66	90	92	125
M16	166	225	229	310
M20	321	435	450	610
M30	1,103	1 495	1,550	2 100
M36	1,917	2 600	2,700	3 675



8.8



10.9

Hydraulic Fitting Torque Values

Tightening Flare Type Tube Fittings

1. Check flare and flare seat for defects that might cause leakage.
2. Align tube with fitting before tightening.
3. Hand-tighten swivel nut until snug.
4. To prevent twisting the tube, use two wrenches. Place one wrench on the connector body and tighten the swivel nut with the second. Torque to values shown.

If a torque wrench is not available, use the FFFT (Flats From Finger Tight) method.

Hydraulic Fitting Torque					
Tube Size OD	Hex Size Across Flats	Torque value		Flats From Finger Tight	
		lbf·ft	N·m	Flats	Turns
3/16	7/16	6	8	2	1/6
1/4	9/16	11–12	15–17	2	1/6
5/16	5/8	14–16	19–22	2	1/6
3/8	11/16	20–22	27–30	1-1/4	1/6
1/2	7/8	44–48	59–65	1	1/6
5/8	1	50–58	68–79	1	1/6
3/4	1-1/4	79–88	107–119	1	1/8
1	1-5/8	117–125	158–170	1	1/8

Values shown are for non-lubricated connections.