

WALLENSTEIN

EMB Manufacturing Inc.
4144 Boomer Line · St. Clements, On · N0B 2M0 · Canada
Ph: (519) 699-9283 · Fax: (519) 699-4146
www.embmfg.com

WX540-LEU Trailer Log Splitter Parts Manual

S/N 2E9US1118ES030216 & After

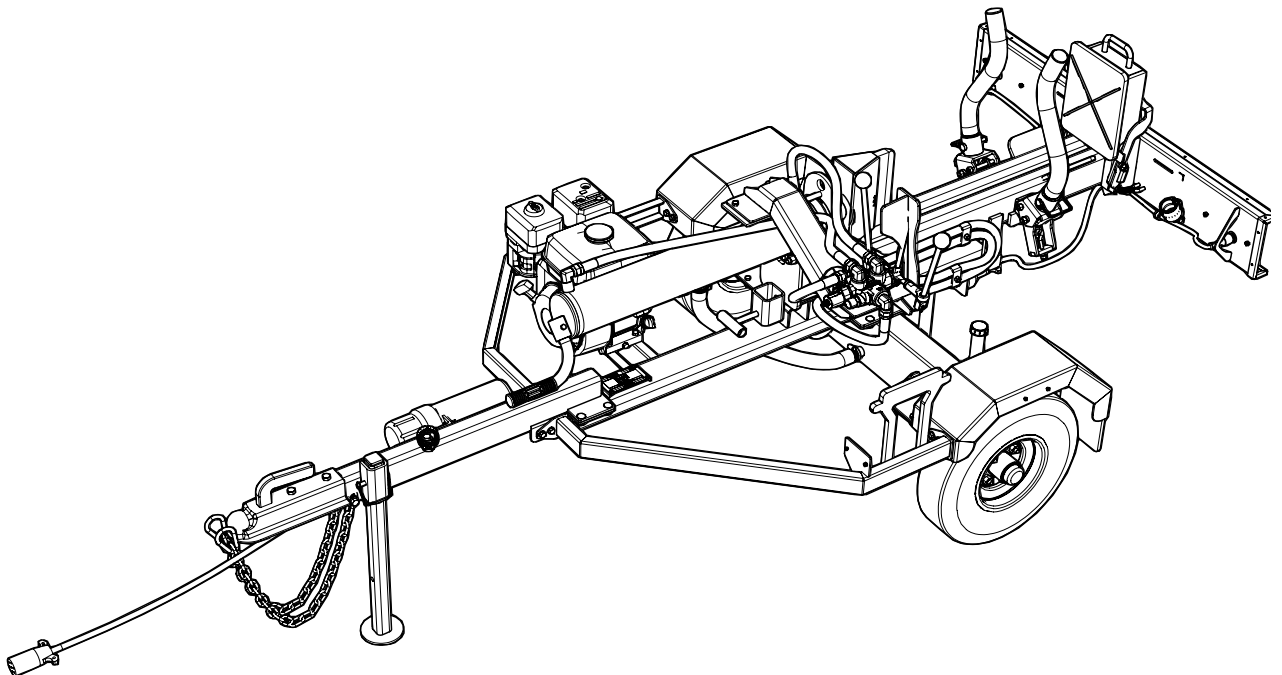

Refer to the operators
manual for safe
operation and
maintenance

Foreword

EMB Mfg. has prepared this parts manual to assist customers in ordering quality OEM replacement parts.

Proper and regular service and replacing old, worn or broken parts with the correct OEM parts are essential to prolonging the life of your EMB product. Please refer to this manual before ordering any replacement parts.

All information contained in this parts manual is based on the latest product specification available at the time of printing this manual. If your product differs from the specifications contained within this manual contact EMB Mfg. for information.

EMB reserves the right to alter specifications on their products at any time.

Reproduction of this parts manual of any kind is prohibited without prior written permission from EMB Mfg.

For parts and information please contact your dealer. If your dealer is no longer available please go to our website: <http://www.embmfg.com> and click on "FIND A DEALER NEAR YOU" for information on a local dealer.

Table of Contents

Bolt Torque.....	4
Hydraulic Fitting Torque	5
Wheel Lug Torque	5
Main Assembly	6
Splitter Bed Assembly.....	7
Trailer Assembly.....	8
Light Bar Assembly	9
Electrical Harness Detail	9
Hub Assembly	10
Hydraulic Assembly	10
Valve Seal Kit	11
Cylinder Detail	11
Hydraulic Hose List	12
Hydraulic Schematic	12
Label Layout.....	13
Accessories.....	14

Bolt Torque

CHECKING BOLT TORQUE

The tables shown below give correct torque values for various bolts and capscrews. Tighten all bolts to the torques specified in chart unless otherwise noted. Check tightness of bolts periodically, using bolt torque chart as a guide. Replace hardware with the same strength bolt.

Torque figures indicated above are valid for non-greased or non-oiled threads and heads unless otherwise specified. Therefore, do not grease or oil bolts or capscrews unless otherwise specified in this manual. When using locking elements, increase torque values by 5%.

* Torque value for bolts and capscrews are identified by their head markings.

ENGLISH TORQUE SPECIFICATIONS

Bolt Diameter "A"	Bolt Torque*					
	SAE 2 (N.m) (lb-ft)		SAE 5 (N.m) (lb-ft)		SAE 8 (N.m) (lb-ft)	
1/4"	8	6	12	9	17	12
5/16"	13	10	25	19	36	27
3/8"	27	20	45	33	63	45
7/16"	41	30	72	53	100	75
1/2"	61	45	110	80	155	115
9/16"	95	60	155	115	220	165
5/8"	128	95	215	160	305	220
3/4"	225	165	390	290	540	400
7/8"	230	170	570	420	880	650
1"	345	225	850	630	1320	970

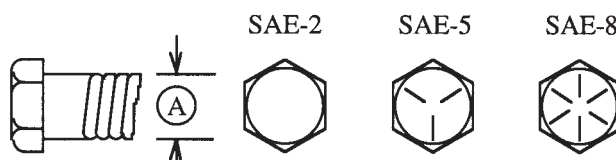

METRIC TORQUE SPECIFICATIONS

Bolt Diameter "A"	Bolt Torque*			
	8.8 (N.m) (lb-ft)		10.9 (N.m) (lb-ft)	
M3	.5	.4	1.8	1.3
M4	3	2.2	4.5	3.3
M5	6	4	9	7
M6	10	7	15	11
M8	25	18	35	26
M10	50	37	70	52
M12	90	66	125	92
M14	140	103	200	148
M16	225	166	310	229
M20	435	321	610	450
M24	750	553	1050	774
M30	1495	1103	2100	1550
M36	2600	1917	3675	2710

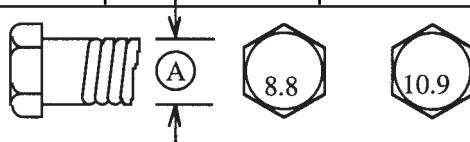

Hydraulic Fitting Torque

Tightening Flare Type Tube Fittings *

1. Check flare and flare seat for defects that might cause leakage.
2. Align tube with fitting before tightening.
3. Lubricate connection and hand tighten swivel nut until snug.
4. To prevent twisting the tube(s), use two wrenches. Place one wrench on the connector body and with the second tighten the swivel nut to the torque shown.

Tube Size OD (in.)	Nut Size Across Flats (in.)	Torque Value*		Recommended Turns To Tighten (After Finger Tightening)	
		(N.m)	(lb-ft)	(Flats)	(Turn)
3/16	7/16	8	6	1	1/6
1/4	9/16	12	9	1	1/6
5/16	5/8	16	12	1	1/6
3/8	11/16	24	18	1	1/6
1/2	7/8	46	34	1	1/6
5/8	1	62	46	1	1/6
3/4	1-1/4	102	75	3/4	1/8
7/8	1-3/8	122	90	3/4	1/8

The torque values shown are based on lubricated connections as in reassembly.

Wheel Lug Torque

It is extremely important safety procedure to apply and maintain proper wheel mounting torque on your trailer axle. Torque wrenches are the best method to assure the proper amount of torque is being applied to a fastener.

Wheel lugs should be torqued before first road use and after each wheel removal. Check and re torque after the first 16Km (10 miles), 40Km (25 miles), and again at 80Km (50 miles). Check periodically thereafter.

Note: Wheel lugs must be applied and maintained at the proper torque levels to prevent loose wheels, broken studs, and possible dangerous separation of wheels from your axle.

- Start all lugs by hand to prevent cross threading.
- Tighten lugs in sequence, per wheel lug torque sequence chart.
- The tightening of the fasteners should be done in stages. Following the recommended sequence, tighten fasteners per wheel torque requirements chart.

Wheel Torque Requirements

Wheel Size	Torque Unit	1st Stage	2nd Stage	3rd Stage
8"	ft-lbs	12 - 20	30 - 35	45 - 55
	Nm	16 - 26	39 - 45.5	58.5 - 71.5
12"	ft-lbs	20 - 25	35 - 40	50 - 60
	Nm	26 - 32.5	45.5 - 52	65 - 78
13"	ft-lbs	20 - 25	35 - 40	50 - 60
	Nm	26 - 32.5	45.5 - 52	65 - 78
14"	ft-lbs	20 - 25	50 - 60	90 - 120
	Nm	26 - 32.5	65 - 78	117 - 156
15"	ft-lbs	20 - 25	50 - 60	90 - 120
	Nm	26 - 32.5	65 - 78	117 - 156
16"	ft-lbs	20 - 25	50 - 60	90 - 120
	Nm	26 - 32.5	65 - 78	117 - 156

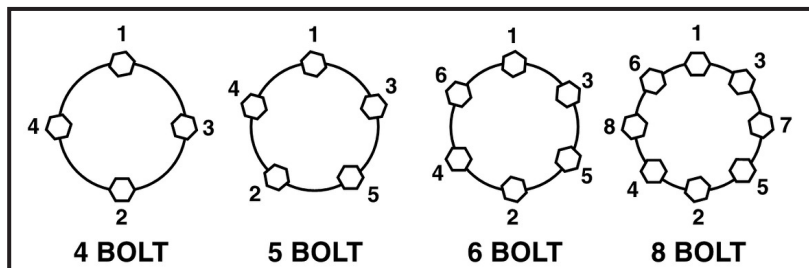

Wheel Lug Torque Sequence

Main Assembly

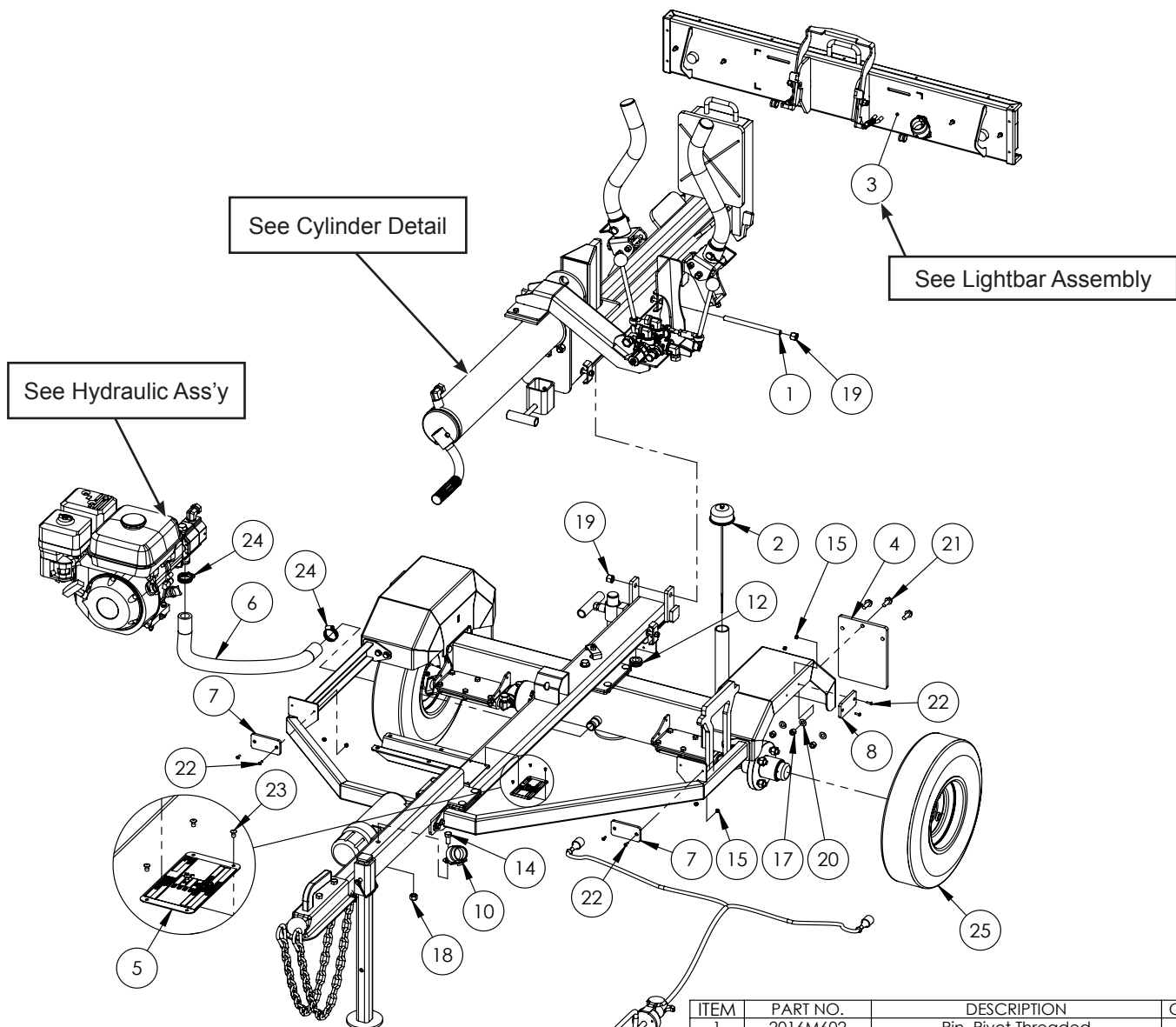

ITEM	PART NO.	DESCRIPTION	QTY
1	2016M602	Pin, Pivot Threaded	1
2	Z55404	Vented Plug Dipstick x 9"	1
3	2054A612	LEU Lightbar Assembly	1
4	2054S655	Rain Flap	2
5	2054S657	CE Stat Plate	1
6	Z52405	Suction Hose, 1" x 22"	1
7	Z61206	Front White Reflex Reflector CE	2
8	Z61207	Side Yellow Reflex Reflector CE	2
9	Z62116	WX540-LEU Light Harness	1
10	Z62121	Euro Plug Holder (13 & 7 pin)	1
11	Z62819	Rubberized Wire Clamp, 1/2"	1
12	Z62822	Rubber Grommet 3/4 x 1/4	1
13	Z71107	Hex Bolt, 1/4NC x 3/4	1
14	Z71410	Hex Bolt, 7/16NC x 1	1
15	Z72202	Hex Lock Nut #8NC	8
16	Z72211	Hex Lock Nut, 1/4NC	1
17	Z72231	Hex Lock Nut, 3/8NC	6
18	Z72241	Hex Lock Nut, 7/16NC	1
19	Z72251	Hex Lock Nut, 1/2NC	2
20	Z73131	Flat Washer, 3/8	6
21	Z76134	Flange Bolt, 3/8NC x 1	6
22	Z78309	Machine Screw, #8-32NC x 1/2	8
23	Z79307	Dome Rivet, 1/8" x 1/8" Alum	4
24	Z79401	Hose Clamp, #16	2
25	Z91321	4.80-8 LRC USATrail E-marked	2

Splitter Bed Assembly

ITEM	PART NO.	DESCRIPTION	QTY.
50	2016S604	Housing, Latch Spring	1
51	2016W603	Handle, Spring Latch	1
52	Z12321	Cotter Pin 3/16 x 2-1/2	1
53	Z32301	Spring 19mm x 79mm Med	1
54	Z73250	Wide Flat Washer, 1/2	1

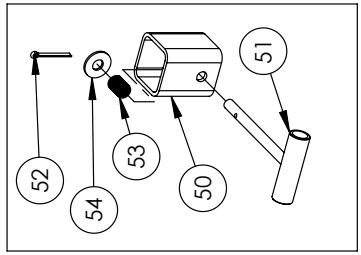

**2016A602 LATCH KIT
(WELDED ON)**

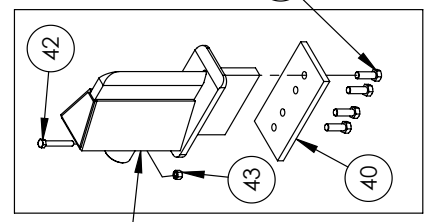
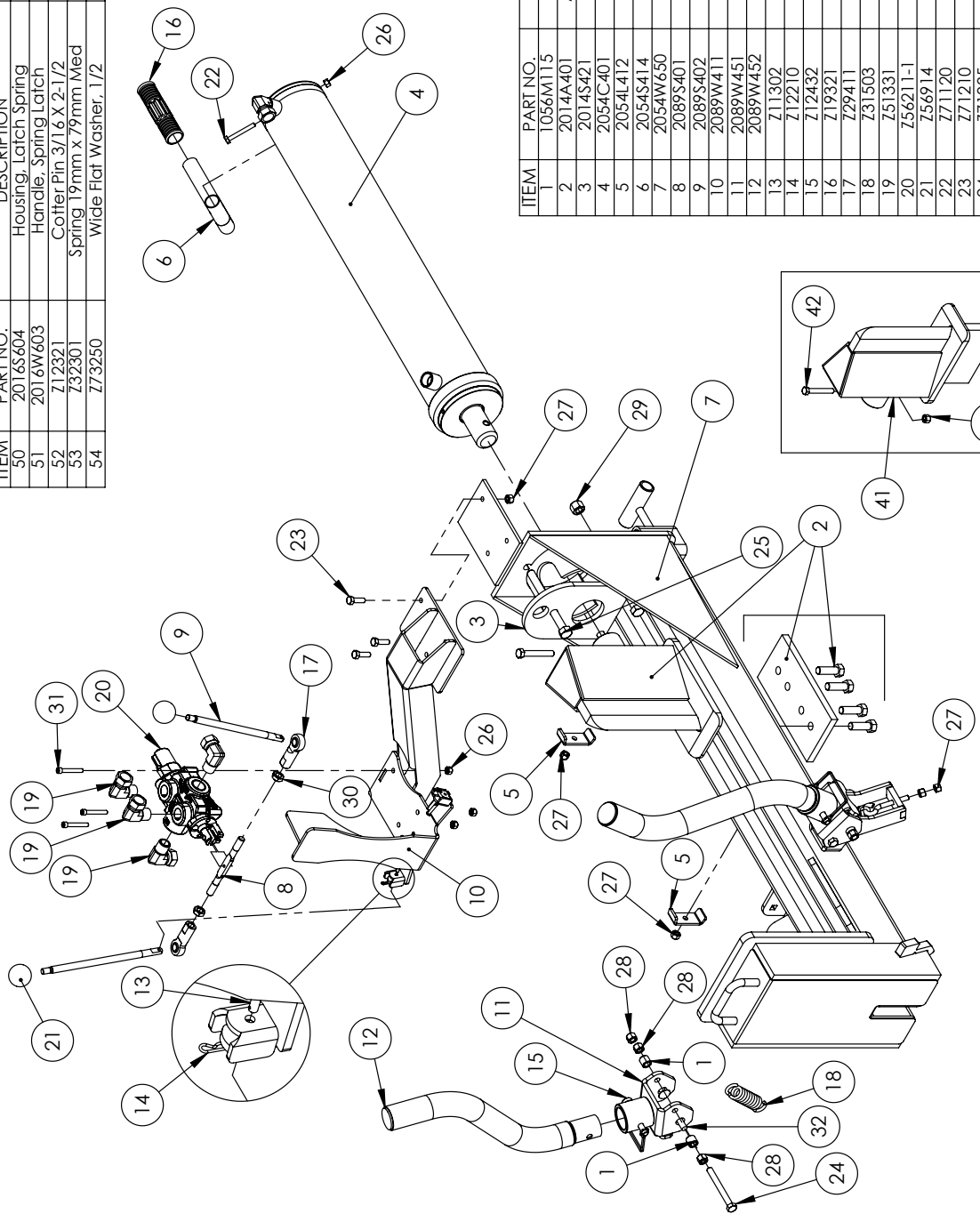

ITEM	PART NO.	DESCRIPTION	QTY.
40	2014S414	Plate, Sliding Wedge Capture	1
41	2014W402	Weldment, Sliding Wedge	1
42	Z71576	Hex Bolt 1/2NF x 1-1/2	5
43	Z72231	Hex Lock Nut 3/8NC	1

ITEM	PART NO.	DESCRIPTION	QTY.
1	1056M115	Spacer, Shredder .580	4
2	2014A401	Assembly, Wide Sliding Wedge	1
3	2014S421	Plate, Cylinder Retaining (Bolt)	1
4	2054C401	Cylinder, 4 x 24 x 1-1/2	1
5	2054L412	Clamp, Two Hose	2
6	2054S414	Handle, Lift	1
7	2054W650	Splitter Base for WX540-LEU	1
8	2089S401	Bar, Connecting	1
9	2089S402	Handle Stem, Euro	2
10	2089W411	Weldment, Angle Base	1
11	2089W451	Arm, Stub Base	2
12	2089W452	Arm, Log Holder	2
13	Z11302	Clevis Pin, 3/16 x 3/4	3
14	Z12210	Hitch Pin Clip, 1/16	3
15	Z12432	Snapper Pin 3/8 x 2-1/2	2
16	Z19321	Grip, 1" x 5"	1
17	Z29411	Rod End Bearing, 7/16	2
18	Z31503	Spring, 1 x 3 x .192	2
19	Z51331	Elbow 90 MP x FFX 0808	4
20	Z56211-1	Brand Valve No Defect	1
21	Z56914	Knob, Handle Kit	2
22	Z71120	Hex Bolt, 1/4NC x 2	1
23	Z71210	Hex Bolt, 5/16NC x 1	3
24	Z71335	Hex Bolt, 3/8NC x 3-1/2	2
25	Z71555	Hex Bolt, 1/2NC x 5-1/2	3
26	Z72211	Hex Lock Nut, 1/4NC	4
27	Z72221	Hex Lock Nut, 5/16NC	9
28	Z72231	Hex Lock Nut, 3/8NC	6
29	Z72251	Hex Lock Nut, 1/2NC	3
30	Z72342	Jam Nut, 7/16NF	2
31	Z75114	SHCS, 1/4NC x 1-3/4	3
32	Z76232	Carriage Bolt, 3/8NC x 1-1/4	4
33	Z76522	Eye Bolt 5/16NC x 2	2

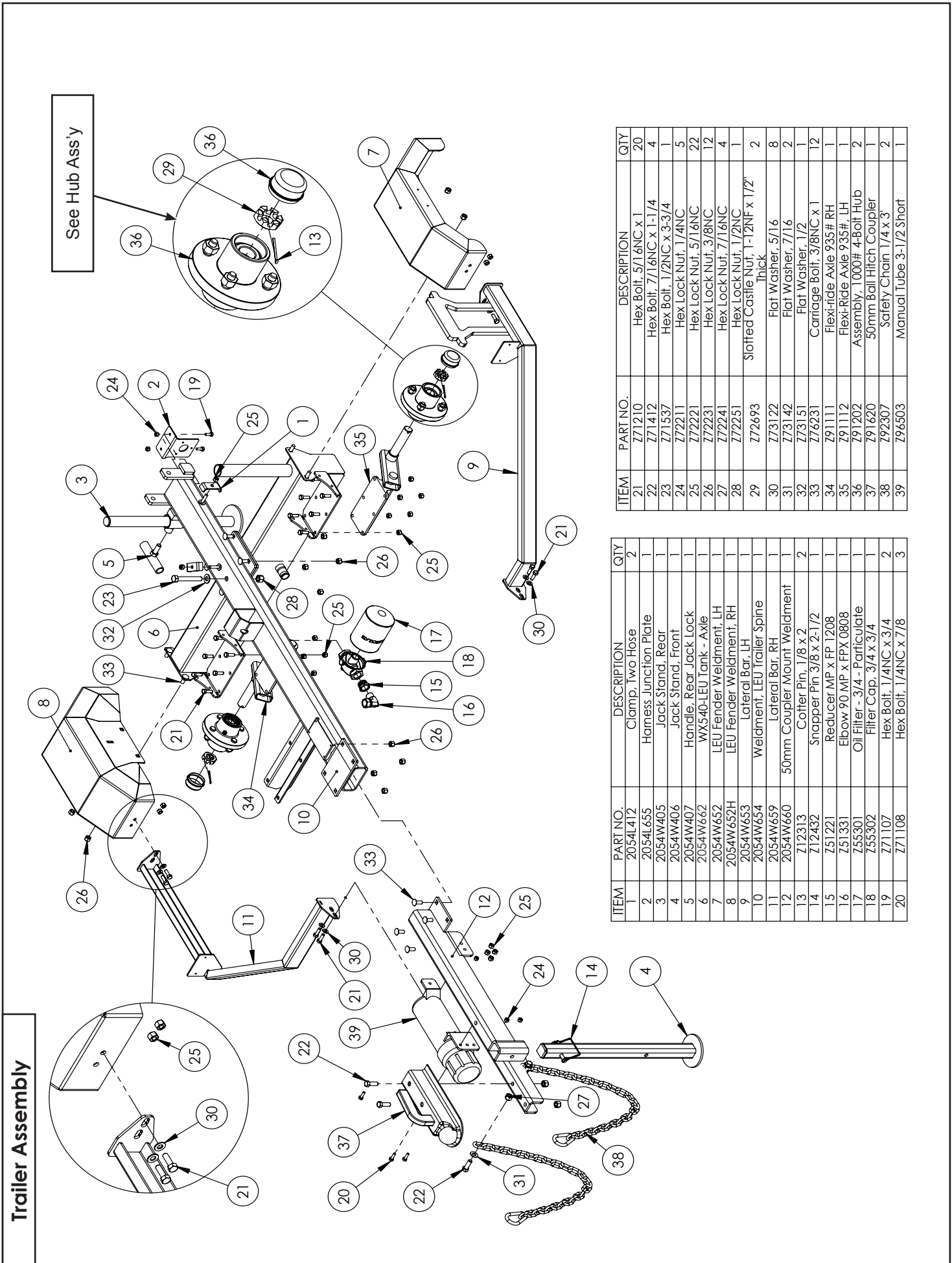

ITEM	PART NO.	DESCRIPTION	QTY
21	Z71210	Hex Bolt, 5/16NC x 1	20
22	Z71412	Hex Bolt, 7/16NC x 1-1/4	4
23	Z71537	Hex Bolt, 1/2NC x 3-3/4	1
24	Z72211	Hex Lock Nut, 1/4NC	5
25	Z72221	Hex Lock Nut, 5/16NC	22
26	Z72231	Hex Lock Nut, 3/8NC	12
27	Z72241	Hex Lock Nut, 7/16NC	4
28	Z72251	Hex Lock Nut, 1/2NC	1
29	Z72693	Slotted Castle Nut, 1-1/2NF x 1/2" Thick	2
30	Z73122	Flat Washer, 5/16	8
31	Z73142	Flat Washer, 7/16	2
32	Z73151	Flat Washer, 1/2	1
33	Z76231	Carriage Bolt, 3/8NC x 1	12
34	Z91111	Flexi-ride Axle 935# RH	1
35	Z91112	Flexi-ride Axle 935# LH	1
36	Z91202	Assembly, 1000# 4-Bolt Hub	2
37	Z91620	50mm Ball Hitch Coupler	1
38	Z92307	Safety Chain 1/4 x 3'	2
39	Z96503	Manual Tube 3-1/2 Short	1

ITEM	PART NO.	DESCRIPTION	QTY
1	2054L412	Clamp, Two Hose	2
2	2054L655	Harness Junction Plate	1
3	2054W405	Jack Stand, Rear	1
4	2054W406	Jack Stand, Front	1
5	2054W407	Handle, Rear Jack Lock	1
6	2054W662	WX540-LEU Tank - Axle	1
7	2054W652	LEU Fender Weldment, LH	1
8	2054W652H	LEU Fender Weldment, RH	1
9	2054W653	Lateral Bar, LH	1
10	2054W654	Weldment, LEU Trailer Spine	1
11	2054W659	Lateral Bar, RH	1
12	2054W660	50mm Coupler Mount Weldment	1
13	Z12313	Cotter Pin, 1/8 x 2	2
14	Z12432	Snapper Pin 3/8 x 2-1/2	1
15	Z51221	Reducer MP x FP 1208	1
16	Z51331	Elbow 90 MP x FPX 0808	1
17	Z55301	Oil Filter - 3/4 - Particulate	1
18	Z55302	Filter Cap, 3/4 x 3/4	1
19	Z71107	Hex Bolt, 1/4NC x 3/4	2
20	Z71108	Hex Bolt, 1/4NC x 7/8	3

Hub Assembly

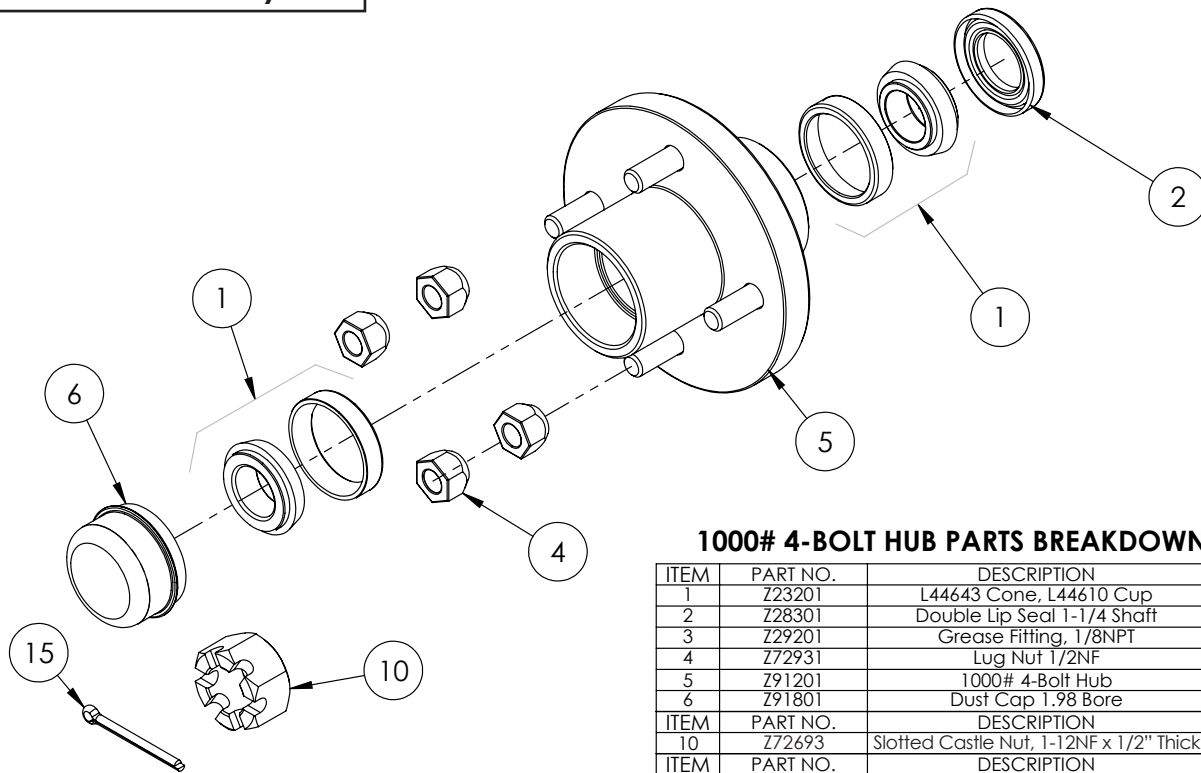

1000# 4-BOLT HUB PARTS BREAKDOWN

ITEM	PART NO.	DESCRIPTION	QTY
1	Z23201	L44643 Cone, L44610 Cup	2
2	Z28301	Double Lip Seal 1-1/4 Shaft	1
3	Z29201	Grease Fitting, 1/8NPT	1
4	Z72931	Lug Nut 1/2NF	4
5	Z91201	1000# 4-Bolt Hub	1
6	Z91801	Dust Cap 1.98 Bore	1
ITEM	PART NO.	DESCRIPTION	QTY
10	Z72693	Slotted Castle Nut, 1-12NF x 1/2" Thick	1
ITEM	PART NO.	DESCRIPTION	QTY
15	Z12322	Cotter Pin 3/16 X 2	1

Hydraulic Assembly

BOM ID	Part No.	Description	Qty
1	Z46406	Shaft Coupler, L075 x 3/4"	1
2	Z46408	Spider, L075	1
3	Z46410	Shaft Coupling, L075 x 1/2"	1
4	Z46521	Key, 3/16" x 3/16" x 7/8"	1
5	Z46592	Woodruff Key, 1/8" x 1/2"	1
6	Z47126	Honda GX160UTQH6, Rope	1
7	Z51331	Elbow 90, MP x FPX 0808	1
8	Z53204	Two-Stage Pump, 11GPM	1
9	Z53801	Pump Mount, PM-5	1
10	Z71207	Hex Bolt, 5/16NC x 3/4"	4
11	Z71273	Hex Bolt, 5/16NF x 3/4"	4
12	Z72221	Hex Lock Nut, 5/16NC	4
13	Z71215	Hex Bolt, 5/16NC x 1-1/2"	4

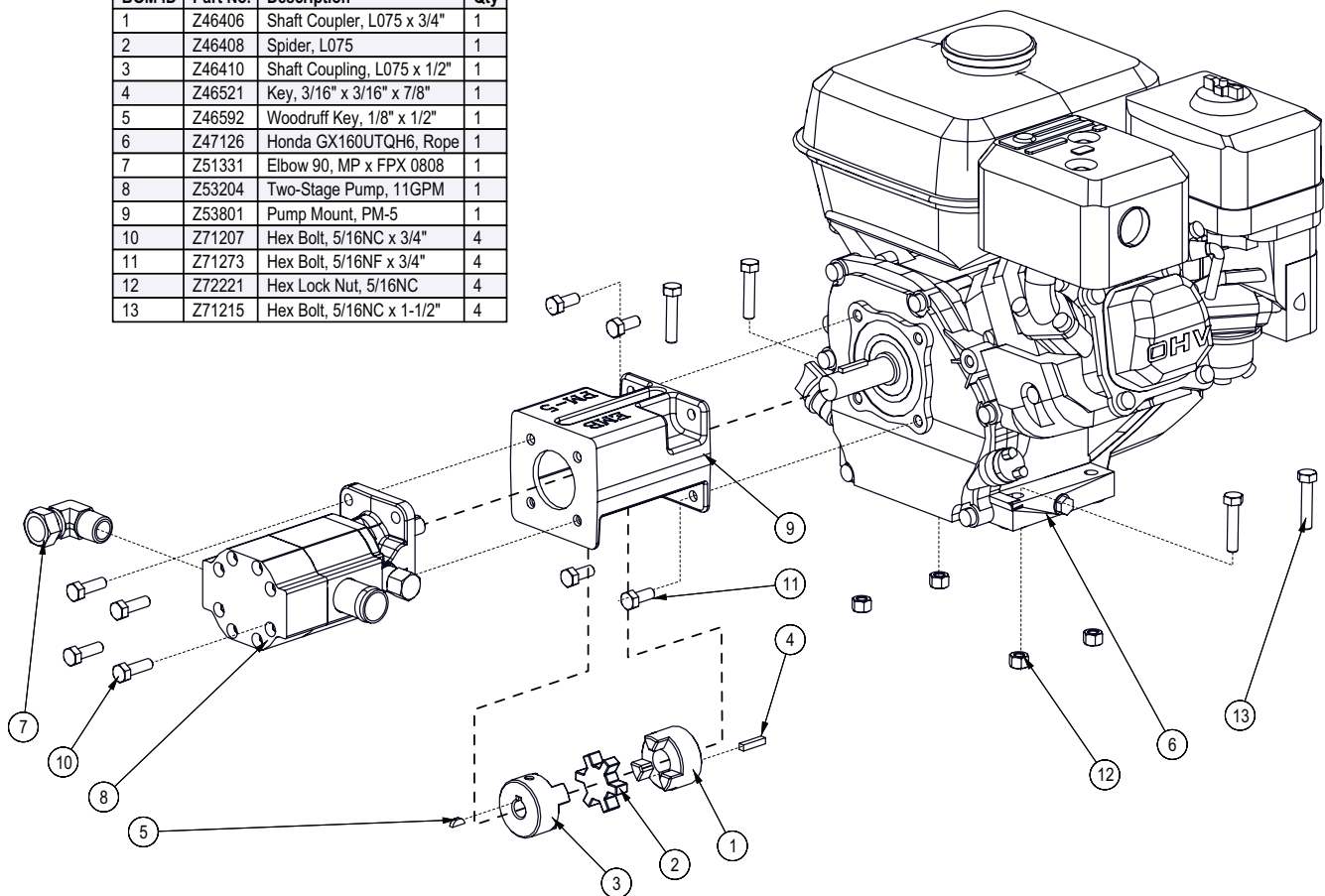

Valve Seal Kit

Seal kit for #Z56211 Valve:
#SDC-K

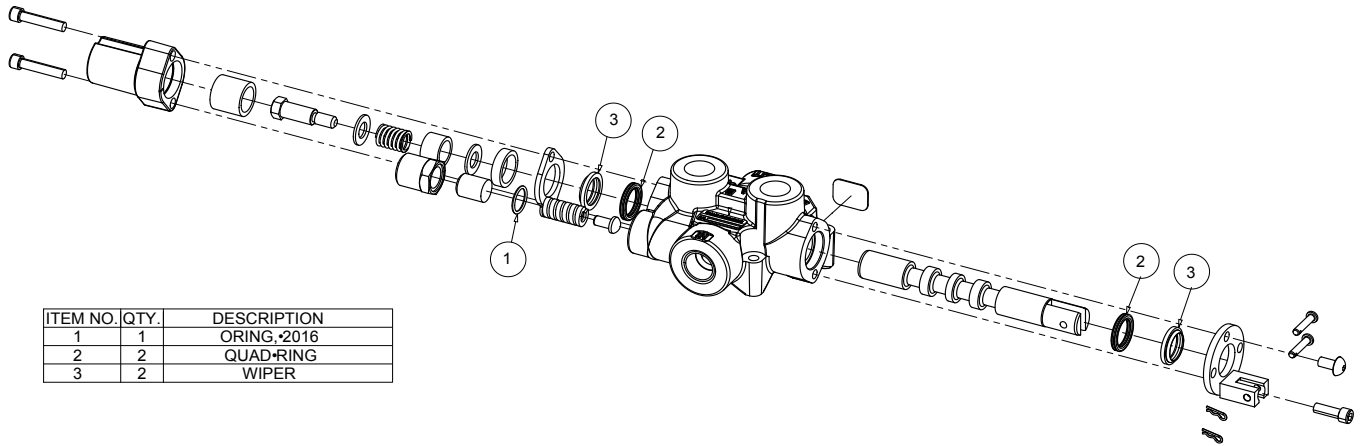

ITEM NO.	QTY.	DESCRIPTION
1	1	ORING, #2016
2	2	QUAD-RING
3	2	WIPER

Cylinder Detail

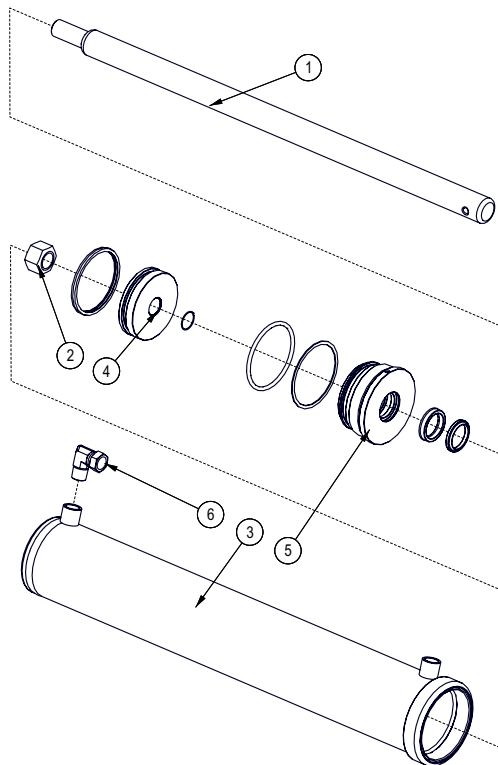

BOM ID	Part No.	Description	Qty
1	2011C1012	Rod, 1-1/2 x 1	1
2	Z72292G8	Hex Lock Nut 1NF Grade 8	1
3	2011C1014	Barrel, 4"	1
4	P100-400SP	Piston, 4" Bore	1
5	G400-150S	Gland, 4" x 1-1/2"	1
6	Z51331	Elbow 90, MP x FPX 0808	1

Hydraulic Hose List

Part Number	Description	Qty
Z52328	1/2" Hose, MP08 x MP08 x 33"SC	1
Z52329	1/2" Hose, MP08 x MP08 x 21"SC	1
Z52331	1/2" Hose, MP08 x MP08 x 72"SC	2
Z52405	Suction Hose, 1" x 22"	1

Hydraulic Schematic

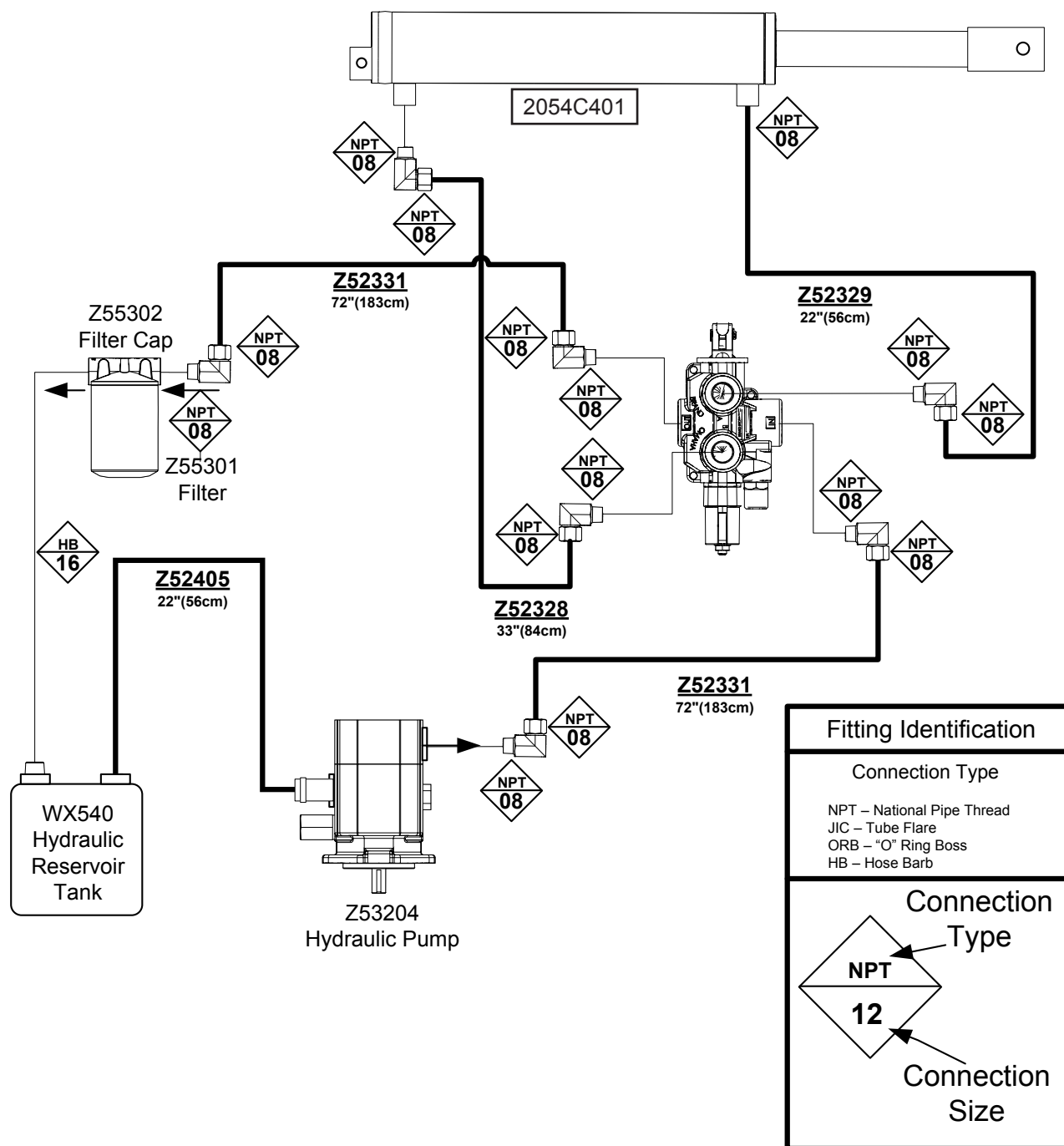

Label Layout



Z94056 x 2

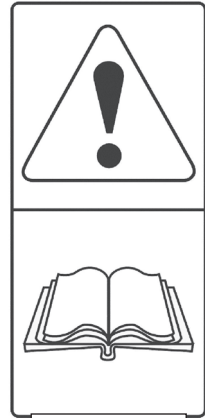

Z94119 x 1



Z94617 x 1



Z94142 x 1

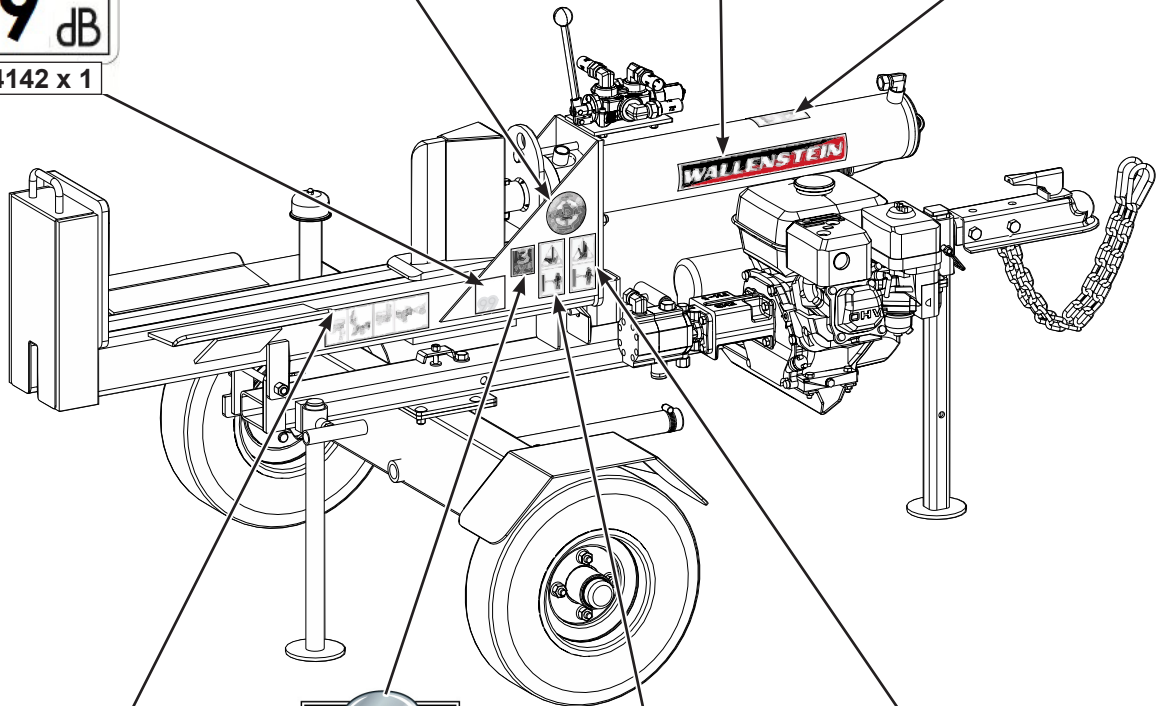

Z94163 x 1

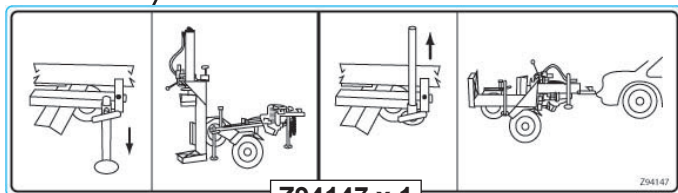

Z94147 x 1



Z94124 x 2



Z94123 x 2

Accessories

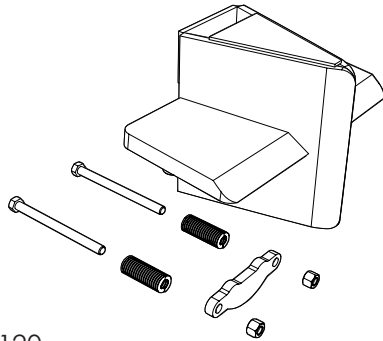

#4120

#4120 - 4 WAY WEDGE

For **WX540-LEU**
 Boost your productivity and make quick work out of logs by splitting four pieces at once. This is an ideal way to save time.

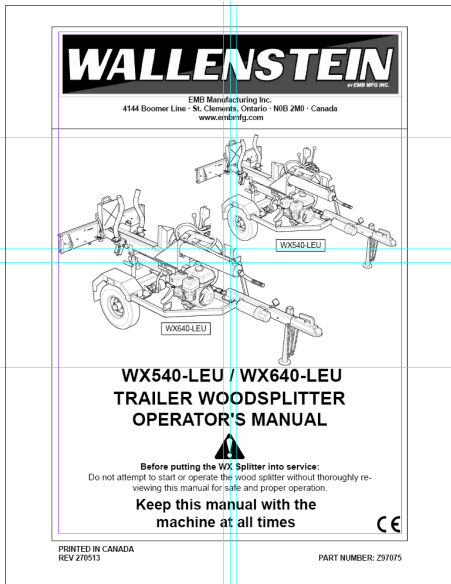

**#Z97075 WX540-LEU
 TRAILER WOOD SPLITTER OPERATOR'S
 MANUAL**

Available as a download at
www.embmfg.com